



WESLEY METHODIST SCHOOL



Student Activity Workbook for The Visual Bible Explorer Series **For Teens** Based on

Genesis - In The Beginning

Vol. 1 From Creation to Abraham

Vol. 2 Isaac, Jacob and Joseph



SAMPLE

The Visual Bible Explorer Series

Student Activity

Workbook

for Teens

Based on

Genesis - In The Beginning

Vol.1 From Creation to Abraham

Vol.2 Isaac, Jacob and Joseph

Peter C. T. Lim



Copyrights



First published in Malaysia in 2018 by Pristine World Sdn Bhd
Copyright © 2018 Pristine World Sdn Bhd, Malaysia

All rights reserved. No part of this publication or multimedia may be reproduced, stored in a retrieval system or transmitted in any form or by any means, electronic, mechanical, photocopying, recording, scanning or otherwise, without the prior written permission of the copyright owner.

Scripture taken from the **HOLY BIBLE, NEW INTERNATIONAL VERSION®**.
Copyright © 1973, 1978, 1984 by International Bible Society. Used by permission of Zondervan Publishing House. All rights reserved.

The “NIV” and “New International Version” trademarks are registered in the United States Patent and Trademark Office by International Bible Society. Use of either trademark requires the written permission of International Bible Society.

Author's Notes and Acknowledgement

This book is designed to be used as a companion student workbook for The Visual Bible Explorer Series, Genesis – In the Beginning.

It is designed for teenage students from 13 to 17 years old. A special section called ‘Challenge Questions’ contains optional questions but are specially designed for the 15-17 year old age group. Additional paper or software tools can be used to present the answers to the ‘Challenge Questions’. Students can also use the extra pages given at the back of the book.

I would like to express my sincere thanks to some people who have contributed to the production of this book: Dr Herbert Tan, from Seminary Theology Malaysia, for editing our content and Dr Tee Meng Yew, from Faculty of Education, University Malaya, for advising on the teaching methods. My thanks also to the Methodist Education Council and Wesley Methodist School Kuala Lumpur for their assistance and support.

Peter C.T. Lim
November 2018

Genesis - In The Beginning

Contents

Lesson 1 Introduction to the Bible and the book of Genesis 4

Genesis Vol.1 From Creation to Abraham

Lesson 2	The Story of Creation	6
Lesson 3	The Garden of Eden	8
Lesson 4	Adam and Eve - Sin enters the World	10
Lesson 5	Cain and Abel	12
Lesson 6	Noah's Ark and the Great Flood	14
Lesson 7	The Tower of Babel	17
Lesson 8	Abram and God's Call	19
Lesson 9	Abram and Lot	22
Lesson 10	The Promise and the Covenant	25
Lesson 11	Abraham Pleads for Sodom	27
Lesson 12	Abraham's Test	30

Genesis Vol.2 Isaac, Jacob and Joseph

Lesson 13	Isaac and Rebekah	32
Lesson 14	Jacob and Esau	34
Lesson 15	Jacob's Journey and Laban's Daughters	36
Lesson 16	Jacob's Return to Canaan	39
Lesson 17	Joseph and his Brothers	42
Lesson 18	The Prisoner and the King	44
Lesson 19	Family Confrontations	47
Lesson 20	Family Reconciliation	50
Lesson 21	Genesis Epilogue - From Tribal Clan to Nation	52
Notes		54

Genesis Volume 1

Chapter 1: INTRODUCTION TO THE BIBLE AND THE BOOK OF GENESIS

Questions

1. What is the meaning of the word Biblios – the Greek word for the Bible?
2. How many books are there in the Old Testament?
3. How many books are there in the New Testament?
4. What is the meaning of the word Testament or Covenant as used in the Bible?
5. Name the first five books of the Old Testament.
6. Name the first five books of the New Testament.
7. Name a few genres or types of writings found in the Bible.
8. After the great flood during Noah's time, who did God make a covenant with to head and lead His people?
9. After the Israelites had been enslaved in Egypt for 430 years, who did God use to lead them out of Egypt?

10. Who led the Israelites into the Promised Land?

11. Who was the first king of Israel?

12. Which king brought the Ark of the Covenant to Jerusalem?

13. Who was the promised Messiah?

Challenge Questions:

1. Write down 3 key themes found in the Bible.

2. What does the word Genesis mean?

3. Who is the writer of the book of Genesis and also the writer of the first five books of the Bible?

4. What are the first five books of the Bible called?

Genesis Volume 1

Chapter 2: THE STORY OF CREATION

Based on chapter 1 in the multimedia book and DVD-R

Bible Truth:

1. Only the Creator God is worthy of our worship.
2. God is perfect.

Objective: Worship the Creator God and be mindful of His righteousness.

Bible Reference: Genesis 1:1-2:3

Memory Verse: "In the beginning God created the heavens and the earth." Genesis 1:1

Question

1. Summarize below what God created each day. Fill in the chart below with the Bible Reference and what was created.

Formlessness given form but still empty	Emptiness filled
<p>Day 1 – Ref: Gen:1:3-5 God created Light</p>	<p>Day 4 – Ref: Gen:1:14-19 Bright objects in space: sun, moon and stars</p>
<p>Day 2 – Ref: _____</p> <p>God created (Upper Expanse) – Air God created (Lower Expanse) - Water</p>	<p>Day 5 – Ref: _____</p> <p>Filled the Upper Expanse (Air) with _____ Filled the Lower Expanse (Water) with _____</p>
<p>Day 3 – Ref: _____</p> <p>God created _____ And _____</p>	<p>Day 6 – Ref: _____</p> <p>God created _____ Finally God created _____</p>
<p>Day 7 – Ref: _____ God _____</p>	

2. List the things God found "good" among His creations from Genesis Chapter 1.

3. What do we learn about God from Genesis Chapter 1?

4. What does it mean to be made in the image of God?

5. Select a project to present

Select your own team and choose one of the following projects to do:

- a. Make a slide or poster presentation of our Solar System or the Universe.
- b. Make a presentation of the most beautiful place you have ever seen or been to and how that experience increased your appreciation for the Creator.

Challenge Questions:

Read Psalms 19.

1. What additional insight does the Psalmist give you about the Creator?

Application Question:

1. Considering God's creation, what do you find amazing?

2. What do you think should be our response to God?

Challenge Application Questions:

Read Job 38:1 – 42:5

1. What additional information does Job give you about how we should relate with our Creator?

Genesis Volume 1

Chapter 3: THE GARDEN OF EDEN

Based on chapter 2 in the multimedia book and DVD-R

Bible Truth:

1. It is our responsibility to take care of God's world.
2. God loves to fellowship with us.

Objective: Take care of God's world and obey His words to us.

Bible Reference: Genesis 2:4-25

Key Lessons:

1. Humans are created with special abilities and responsibilities. We are given the breath of God to live and are created in His image. We are given the task of caring for His creation.
2. God loves mankind. After He made man and woman, He cared for them and made the first covenant with humankind. Adam and Eve could live in the paradise Garden as long as they obeyed God.

Memory Verse: "When I consider your heavens, the work of your fingers, the moon and the stars, which you have set in place, what is man that you are mindful of him, the son of man that you care for him?"
Psalms 8:3-4

Questions

Look for the following words in the puzzle:

GARDEN
EDEN
BREATH OF LIFE
PERFECTION
EUPHRATES
ADAM
EVE
MARRIAGE
MAGE OF GOD
FRUIT
TREE OF LIFE



Challenge Questions:

1. Note the instructions and responsibility given to Adam in verses 15-17. What do they reveal about the life God originally intended for us?
2. What is the significance of Adam naming all the creatures and his wife?
3. In your own words what do you think verse 24 teaches about marriage?
4. What commands did God give to man when he placed him in the garden? What was it that he could and could not do and what were the consequences for disobedience?

Application Question:

1. How can we take care of our Garden of Eden – in our house, our neighbourhood, our town, state and country?
2. How are we made in the image of and likeness of God as per verse 26 of Genesis Chapter 1?

Challenge Application Questions:

1. What is expected of us in carrying this image of God? How does this passage help you understand who you were created to be?

Genesis Volume 1

Chapter 4: ADAM AND EVE - SIN ENTERS THE WORLD

Based on chapter 3 in the multimedia book and DVD-R

Bible Truth: God desires our fellowship and obedience to Him.

Objective: To have fellowship with God, we need to learn His commands and obey Him.

Bible Reference: Genesis 3:1-24

Key Lessons:

1. God is described in the Bible as a spiritual being as well as a personal being. Although He is all powerful, He fellowships with us on a personal level.
2. God gives humans the freedom of choice. Obedience leads to life. Disobedience leads to judgment and separation from God.

Memory Verse: In verse 8 of Genesis Chapter 3, God is said to be walking in the garden. This is an example of personification where human traits are attributed to God. We know that God is Spirit (John 4:24)

Questions

1. From Genesis Chapter 1 and 2 the verses where the Bible uses human traits to describe what God did.
2. Describe the transformation of Adam and Eve that occurred when they ate of the tree of knowledge of good and evil. What was different about them after they ate of the tree?
3. Write the punishment given to:
 - a. Adam
 - b. Eve

c. The serpent

4. Fill in the chart where God spoke, the serpent lied, Eve's reply and the difference.

God said (Gen 2:16-17) _____ _____ _____	Satan said (Gen 3:1) _____ _____ _____	Eve said (Gen 3:2-3) _____ _____ _____	The discrepancy God did not say 'you must not touch it.'
God said (Gen 2:16:17) _____ _____ _____	Satan said (Gen 2:4-5) _____ _____ _____	Eve & Adam did _____ _____ _____	The discrepancy _____ _____ _____

Application Question:

1. Review question 4 above. Are we more likely to believe half-truths than complete lies? In what way can half-truths be more dangerous?
2. What can we do to avoid or protect ourselves from being deceived into doing things we know are wrong?

Challenge Application Questions:

1. Explain with New Testament verses, what God has given us today to resist the temptations of the devil and how can we make use of it.
2. What hope does Genesis 3:15 give us? Explain in your own words what this verse means.

Genesis Volume 1

Chapter 5: CAIN AND ABEL

Based on chapter 4 in the multimedia book and DVD-R

Bible Truth: God gives us chances to repent.

Objective: Be aware of our attitude towards God when we know we have sinned against Him.

Bible Reference: Genesis 4:1-26

Key Lessons:

1. Cain was warned to obey God. But he refused to listen and this led him to committing the terrible sin of murder.
2. God is the judge who sees everything. He holds us accountable for all our actions. Cain thought no one saw his crime but God saw it and punished Cain.

Memory Verse: "Be kind and compassionate to one another, forgiving each other, just as in Christ God forgave you." Ephesians 4:32

Read Genesis 4

Understanding the Lesson

1. Fill in the family tree chart. Refer to the Bible references. Also fill in a short description of what they did or were famous for as described in the Bible.

Adam and Eve family tree until the descendants of Cain and Seth

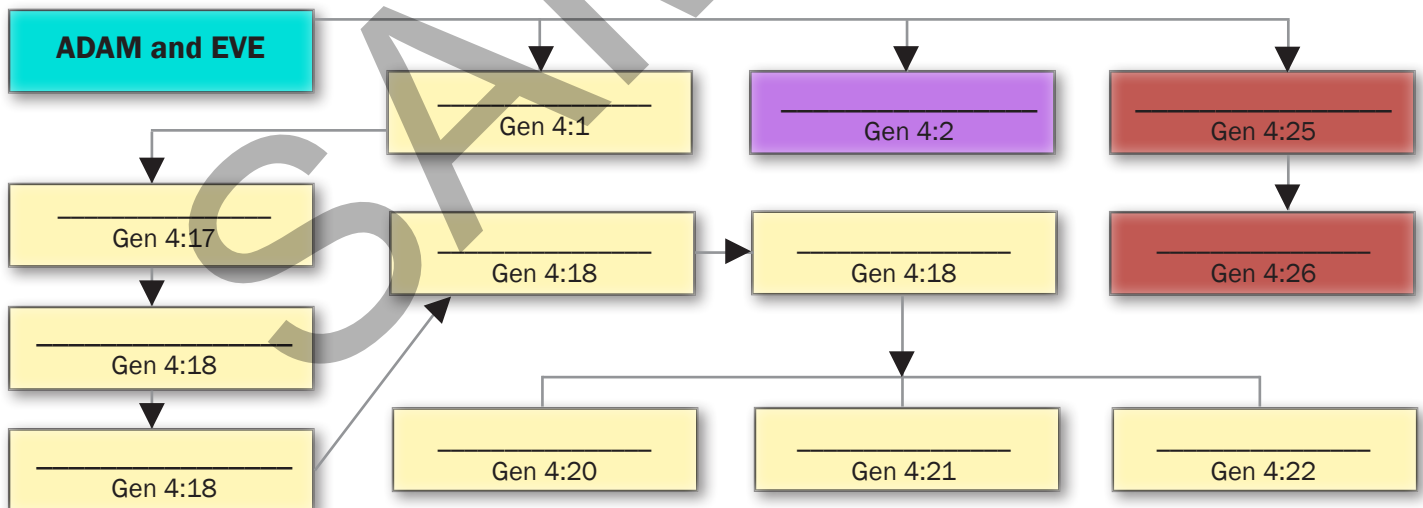

2. In verses 1-5 what do we learn about the two brothers and their offerings?

3. God had advised Cain to “do what is right” or he would become a servant to sin. What prevented him from listening to God? What did God mean when He said “do what is right”? Why was it wrong for Cain to be come and stay so angry?
4. What did Cain do to Abel?
5. What does 1 John 3:12 teach us about Cain’s motives?

Fill in the blanks

1. When God asked Cain ‘where is your brother’, Cain replied, ‘Am I my brother’s _____?’
2. After Cain was punished he went to live in the land of _____.
3. Cain named a city after his son _____.
4. Lamech married two women named _____ and _____.
5. _____ was the father of those who play stringed instruments and pipes.
6. _____ became an expert in forging tools of bronze and iron.
7. Complete the sentence ... ‘if Cain is avenged seven times, then _____ is avenged seventy seven times?’
8. God granted Adam and Eve another child in place of Abel and his name was _____.

Challenge Question:

What is the meaning and purpose of Lamech’s poem or song? What does this song portray about Lamech’s character? How does the song portray the progress of sin from Adam to Cain to Lamech? Think about how it actually gets worse when we allow ourselves to continue sinning.

Application Question:

1. If we are in a situation like Cain and God has given us a warning, how should we respond?
2. Lamech had a revenge policy written into a song. What did Jesus say about taking revenge on others who have sinned against us? Refer to Matthew 8:20-22. How can we put this into practice without allowing people to simply ‘walk over us’? Give Bible references to support your answer.

Genesis Volume 1

Chapter 6: NOAH'S ARK AND THE GREAT FLOOD

Based on chapter 5 and 6 in the multimedia book and DVD-R

Bible Truth: God punishes sin but saves the faithful followers

Objective: Stay faithful to God even when others are not.

Bible Reference: Genesis 6, 7 and 9

Key Lesson: Noah had never built an Ark before. His only qualification for this great task was that he had faith, and he loved the Lord. Because of this, God chose Him to save creation. The story of Noah and the Ark is a depiction of the story of salvation available through Jesus (1 Peter 3:20)

Memory Verse: "For there is one God and one mediator between God and mankind, the man Christ Jesus, who gave himself as a ransom for all people. This has now been witnessed to at the proper time." 1 Timothy 2:5-6

Read Genesis chapter 6:1 – 7:15

Understanding the Lesson

1. From Genesis Chapter 4, describe how the human race had progressed.
2. From Genesis Chapter 6, how had sin become worse since the time of Adam? List some examples of the kind of sin that upset God.
3. For what reasons might the revelation of God to Noah have seemed unbelievable to Noah, his wife and children?

4. Find these words in the word maze:

ARK
 BUILD
 STORE
 FOOD
 GREAT FLOOD
 ANIMALS
 FLOOD GATES
 BLAMELESS
 SHEM
 HAM
 JAPHETH
 ARARAT
 DOVE
 RAINBOW



(Optional)

Form teams of 2 or 3 and prepare a Project Presentation to be presented in the next class.

Imagine you are reporter in the time of Noah. Write a few news paper articles including a headline on the progress of Noah's building of an ark.

Insert Advertisement	Headline
Main story	
Interview Noah	Interview several by-standers

Application Question:

1. How was Noah different from his contemporaries?

2. What difference did he make in the world and what can we learn from Noah?

Challenge Application Questions:

1. What did God intend to do at first to the world and what did God plan to do later through Noah?

2. How is the story of Noah a picture of what Jesus would achieve in the New Testament?

3. What does this tell us about how, by our words and actions, we can make a difference in the lives of other people and of society?

Genesis Volume 1

Chapter 7: THE TOWER OF BABEL

Based on chapter 7 in the multimedia book and DVD-R

Bible Truth: Being proud and disobeying God brings judgement.

Objective: To recognise pride in our lives and to submit our plans to God.

Bible Reference: Gen 11: 1 - 9

Key Lessons: Humankind disobeys God by refusing to spread out and fill the earth. Instead they build a tower in defiance of God. God judges them for their pride by frustrating their plans.

Memory Verse: "Pride goes before destruction, a haughty spirit before a fall." Proverbs 16:18

Read Genesis 10:1 - 11:9

Often attributed to Nimrod, the Tower of Babel (Gen. 11:19) was not a "Jack and the Beanstalk" type of construction, where people were trying to build a structure to get into heaven. Instead, it is best understood as an ancient ziggurat (Assyrian "mountaintop"), as the one pictured at ancient Ur of the Chaldees, Abraham's hometown (Gen. 11:31). A ziggurat was a man-made structure with a temple at its top, built to worship the host of heaven.

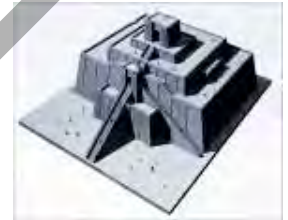

The name 'Nimrod' comes from the Hebrew verb marad, meaning "rebel."

Source: by Dr David P. Livingston, Associates for Bible Research at <http://www.christiananswers.net/dictionary/nimrod.html>

Understanding the Lesson

1. Based on Genesis Chapter 11, what motivated the people to build the Tower of Babel?
2. Why were the people wrong to build the tower?
3. From Genesis Chapter 11, what 2 things did God cause to happen to those who were building the tower?

4. How were Nimrod and Cain similar?

Challenge Question:

Which human characters that we have studied in Genesis from Chapter 1 to 11 have been _____ and give your reason.

- a. The most disobedient? _____
- b. The most patient? _____
- c. The one with the most self-pity? _____
- d. The most humble? _____
- e. The most proud? _____
- f. The most naïve? _____

Application Question:

1. In your observation of current events describe the possible building plans of modern and/or different "Tower of Babels".
 - a. among leaders of nations? Can you think of some rebellious, God-defying, Tower-of-Babel projects in recent history?

 - b. among ordinary people?

2. In what ways can we be tempted or become guilty of building our own 'Towers of Babel'? What should we do?

Challenge Application Questions:

1. Why was it wrong for the people of Babel to build a Tower to honour themselves? Why was God not happy with their project?

Genesis Volume 1

Chapter 8: ABRAM AND GOD'S CALL

Based on chapter 8 in the multimedia book and DVD-R

Bible Truth: Abram obeyed God but he also experienced doubt and fear and sinned by lying.

Objective: Obey God's call and trust Him all the way.

Bible Reference: Genesis 12:1 - 20

Memory Verse: "I press on toward the goal to win the prize for which God has called me heavenward in Christ Jesus." Philippians 3:14



Key Lessons:

1. God's covenant to make a great nation of people is now with Abram. Abram obeys God's call to leave his comfortable home for the Promised Land, knowing that life would be difficult.
2. Although Abram should not have lied about his wife Sarai to the Pharaoh in Egypt, God still protected him. Abram would learn from this lesson to trust God completely.

Read Genesis 12:1-20

Understanding the Lesson

1. Reading from the NIV version of the Bible, how many times does the word 'I will' and 'you' appear in the first three verses of Genesis Chapter 12? What does this tell you about God's calling for Abram?
2. Considering Abram's call, in what way did Abram and Sarai have to exercise their faith?

3. Did Abram do the right thing by telling Pharaoh, the king of Egypt that Sarai was his sister?

Gen 12:1-3 THE LORD SAID TO ABRAM

Go out from _____ country,
_____ relatives and
_____ father's house to that land that

_____ show _____.
_____ make _____ into a great nation, and
_____ bless _____;
_____ make _____ name great, and you _____ be a blessing

I _____ bless those who bless _____ curse those who treat
_____ with contempt and all the peoples on earth.
_____ be blessed through _____.

4. How did God protect Abram? Do you think this Pharaoh was smart in letting Abram go?

5. How did God save Abram from his own deception?

6. How has God blessed all the people on earth through Abraham (verse 3)? Read Acts 3:25 and Galatians 3:8 to develop your answer.

Challenge Question:

What instruction did Abram receive from God in Gen 12:1 and who did he bring along with him. Why do you think he did what he did? Give your reasons.

Application Question:

1. When we encounter challenges, do we take matters into our own hands depending on our own wisdom instead of relying on God? What should Abram have done when he went to Egypt and what can we do in challenging situations?
2. How can we better prepare ourselves for a time when we may have challenges and opportunities?

Challenge Application Questions:

1. Why do you think Abram was chosen and called by God?

Genesis Volume 1

Chapter 9: ABRAM AND LOT

Based on chapter 9 in the multimedia book and DVD-R

Bible Truth: God is the protector and provider of His people.

Objective: Learn to rely on God and not on worldly wealth or power.

Bible Reference: Genesis 13:1 - 14:24

Key Lessons:

1. Abram is gentlemanly and lets Lot choose the best land.
2. Abram is not afraid of his enemies although he is outnumbered. He defeats the Northern kings in battle and brings home loot and hostages.
3. Abram rejects the King of Sodom's offer to keep the loot. He does not need help from wicked kings. God is his provider and greatest ally.

Memory Verse: "Then he said to them, "Watch out! Be on your guard against all kinds of greed; life does not consist in an abundance of possessions." Luke 12:15

Questions

Fill in the blanks.

1. Quarrelling arose between the _____ of Abram and Lot.
2. Abram gave Lot first choice of pasture. To the plains or to the hillside. Lot chose the _____.
3. Which two cities were nearby the area that Lot had chosen? _____ and _____.
4. King _____ and three other kings formed an alliance and invaded the cities of Canaan.
5. The five biggest and wealthiest cities in Canaan were _____, _____, _____, _____, and _____.
6. Abram assembled _____ born in his household and together with his allies rescued Lot and hostages from Sodom.
7. The king of Salem _____, came out to bless Abram. He accepted a tenth of the goods he had brought back from his victory.
8. The king of Sodom offered to let Abram keep all the loot but Abram's reply to the king of Sodom was:

“ _____

_____ ”

Challenge Question:

1. Did Abram have to give Lot first choice of pasture?

2. How was Abram different from Lot? Give references to support your answer.

(Optional)

Write a Newspaper article of what happened in Genesis 14. Include the topics below:

- What happened. Briefly cover Gen 14:1-16 but centre the story around Gen 14:17-24.
- Why did Abram accept the food offered by Melchizedek king of Salem and not accept the proposal made by the king of Sodom?
- Why did Abram offer a tithe to Melchizedek?
- Why do you think Lot returned to Sodom rather than to follow Abram?

Make your own slide or poster

<h2>Sodom Star Tribune</h2>	
<div style="border: 1px solid black; padding: 5px; display: inline-block;">Headline</div>	

Application Question:

1. How had Abram's response to challenges changed in this story as compared to his encounter with Pharaoh? What had changed in Abram and what can we learn from this?
2. What are some New Testament references about who Melchizedek represents? What can we learn
3. In Gen 14:21-24 Abram had an encounter with the King of Sodom. How did Abram's actions show his faith in God? What can we learn from this?

Challenge Application Questions:

1. Why do you think Abram rejected the offer of the King of Sodom?
2. What does this teach us about working with people we know who have wicked plans? How can we protect ourselves from them?

Genesis Volume 1

Chapter 10: THE PROMISE AND THE COVENANT

Based on chapter 10 and 11 in the multimedia book and DVD-R

Bible Truth: God fulfills His promises in His own time. God makes a formal Covenant with Abraham.

Objective: Learn to wait and trust in God. When God promises to bless us, we have to do our part by obeying Him.

Bible Reference: Genesis 15, 16 & 17

Key Lesson: God promises Abram that he will have an heir. While Abram is willing to wait for God to keep His promise, Sarai is impatient and decides to do things her way. This only causes problems because Ishmael is not the promised son. God would fulfill His promise in His own time. God's original promise is confirmed in a formal Covenant. Abram and Sarai are given new names - Abraham and Sarah. Part of this Covenant requires Abraham to do something risky - circumcision.

Memory Verse: "Know therefore that the LORD your God is God; he is the faithful God, keeping his covenant of love to a thousand generations of those who love him and keep his commandments."
Deuteronomy 7:9

Questions

Use the given code and fill in the blanks.

A	B	C	D	E	F	G	H	I	J	K	L	M	N	O	P	Q	R	S	T	U	V	W	X	Y	Z
20	22	18	13	11	26	7	23	9	10	5	12	4	14	25	16	17	3	19	1	21	2	8	24	15	6

___ ___ ___ ___ ___ ___ ___ ___ ___ ___ ___ ___ ___ ___ ___
 7 25 13 20 18 18 11 16 1 11 13 20 22 3 20 4 22 11 18 20 21 19 11 25 26

___ ___ ___ ___ ___ ___
 23 9 19 26 20 9 1 23

___ ___ ___ ___ ___ ___ ___ ___ ___ ___ ___ ___ ___
 23 20 7 20 3 22 25 3 11 20 19 25 14 14 20 4 11 13 9 19 23 4 20 11 12

___ ___ ___ ___ ___ ___ ___ ___ ___ ___ ___ ___ ___ ___ ___ ___ ___ ___ ___ ___
 7 25 13 4 20 13 11 20 18 25 2 11 14 20 14 1 8 9 1 23 20 22 3 20 4

___ ___ ___ ___ ___ ___ ___ ___ ___ ___ ___ ___ ___ ___ ___ ___
 20 22 3 20 4 8 20 19 7 9 2 11 14 20 14 11 8 14 20 4 11

___ ___ ___ ___
 20 22 3 20 23 20 4

Challenge Question:

1. Search a dictionary or Google for the meaning of the word 'Covenant'. Explain in your own words, what was the covenant that God made with Abraham as described in Genesis 17:
 - What did God promise He will do for Abraham
 - What was Abraham to do
 - Who were involved in this covenant and who were not

2. What is another word for 'Testament'?

Application Questions:

1. Circumcision was a sign of the people of Israel making a covenant with God. What did it symbolise?
Read: a. Deuteronomy 30:6
b. Ezekiel 44:7

Today, as Christians, how can we receive this circumcision of the heart.

Refer to Colossians 2:11-15.

What bad habits can God help us "cut out" and what good habits can we build into our life with God's help?

2. Imagine you are now a father who is going to write a covenant with your son or daughter.

I, (your name) _____ covenant with my beloved son/daughter _____ on this date _____ I will do this for you _____

_____ You will do this for me _____

_____ And this is the sign that you are my son or daughter _____

_____ How long will this covenant last _____

_____ This is my seal to confirm the covenant _____.

Now imagine you are the son or daughter reading this covenant. Will you agree to it and sign?

Use more paper if needed.

Genesis Volume 1

Chapter 11: ABRAHAM PLEADS FOR SODOM

Based on chapter 12 and 13 in the multimedia book and DVD-R

Bible Truth: God tells Abraham His plans so that Abraham will teach his children God's way.

Objective: Praying to God for others in need.

Bible Reference: Genesis 18

Key Lessons:

1. The Lord speaks to Abraham as a friend telling him of His plans.
2. God values human life. God goes to see the sinfulness of Sodom for Himself before punishing the city. He allows Abraham to negotiate for the rescue of Lot.

Memory Verse: "For I have chosen him, so that he will direct his children and his household after him to keep the way of the LORD by doing what is right and just, so that the LORD will bring about for Abraham what he has promised him." Genesis 18:19

Questions

1. Look at the sentence and type in the letter that is 2 letters behind it in the alphabetic sequence and complete the sentence. Example if you see the letter 'C' then write 'A' if you see 'A' then write in 'Y'.

_ _ _ _ _ _ _ _ _ _ _ _ _ _ _ _ _ _ _ _ _ _ _ _ _ _
 V J G N O T F C R R G C T G F V Q C D T C J C O K P
 _ _ _ _ _
 O C O T G
 _ _ _ _ _ _ _ _ _ _ _ _ _ _ _ _ _ _ _ _ _ _ _ _ _ _
 U C T C J A Q W T Y K H G Y K N N D G C T A Q W C
 _ _ _ _ _
 U Q P
 _ _ _ _ _ _ _ _ _ _ _ _ _ _ _ _ _ _ _ _ _ _ _
 C D T C J C O Y K N N U W T G N A D G E Q O G C
 _ _ _ _ _ _ _ _ _ _
 I T G C V P C V K Q P
 _ _ _ _ _ _ _ _ _ _ _ _ _ _ _ _ _ _ _ _ _ _ _ _ _ _
 C N N P C V K Q P U Q P G C T V J Y K N N D G
 _ _ _ _ _ _ _ _ _ _ _ _ _ _ _
 D N G U U G F V J T Q W I J J K O
 _ _ _ _ _ _ _ _ _ _ _ _ _ _ _ _ _ _ _ _ _ _ _
 V J G Y C A Q H V J G N O T F

2. Who were the three men who came to visit Abraham? What did Abraham do to welcome them into his home?

3. From Genesis 18:19 what responsibility has God given to Abraham?

4. How many people were saved from Sodom?

5. How was Sodom destroyed?

Challenge Question:

1. Why did Sarah laugh when she heard that she would bear a son? Did she finally believe the three men? Read Hebrews 11:6, 11:11 and Luke 1:45. Why was it important for her to believe?

2. Since God knew how many righteous people there were in Sodom, why did He let Abraham negotiate with Him about sparing Sodom if a number of righteous people could be found there?

Application Questions:

1. How can we use Abraham's example to help us in our prayers?

Genesis Volume 1

Chapter 12: ABRAHAM'S TEST

Based on chapter 14 in the multimedia book and DVD-R

Bible Truth: God provides when we trust in Him.

Objective: Learn to place God above everything else.

Bible Reference: Genesis 21:1 - 20, Genesis 22:1-19

Memory Verse: "The LORD is my light and my salvation— whom shall I fear? The LORD is the stronghold of my life— of whom shall I be afraid?" Psalm 27:1



Key Lesson: Isaac's birth brought tension between Hagar and Sarah. Abraham is worried for Ishmael, but God tells Abraham to do as Sarah suggested. God will provide for Ishmael. Abraham's willingness to obey God and sacrifice Isaac was proof that he placed God above everything else in his life.

Questions

Read Genesis 22:1-19 and fill in the blanks.

1. Sarah bore Abraham a son and he was named _____.
2. One day, God called Abraham to offer his son as a sacrifice in the region of _____.
3. The next day, Abraham saddled a donkey and took his son and two _____.
4. Their journey to the place of sacrifice would take _____ days.
5. Before Abraham could slay his son on the altar of sacrifice, _____ stopped him.
6. Finally, what animal was sacrificed? _____.
7. Abraham named the place _____.
8. After that, Abraham, his son and the servants journeyed to _____ where they stayed for a time.

9. From Genesis 22:1-10 can you describe Isaac's attitude towards his father and towards God? Remember that Abraham was over 100 years old and Isaac was a young teenager at that time. Could Abraham have physically forced Isaac to do anything that Isaac didn't want to?
-
-

Challenge Question:

1. What do you think was God's purpose in testing Abraham? Read also Hebrews 11:17-19

2. What did God promise Abraham as a reward for his faith?

Application Questions:

1. Is there any challenging thing God is asking you to do to obey Him?

2. What have you learnt about the character of Abraham in this story and how can you apply it?

Genesis Volume 2

Chapter 13: ISAAC AND REBEKAH

Based on chapter 15 in the multimedia book and DVD-R

Bible Truth: We can't see the future but God has already prepared it for us.

Objective: Learn to let God lead the way.

Bible Reference: Genesis 23:1 - 25:28

Key Lessons:

1. Abraham and his servant both trust God to find the right wife for Isaac.
2. Rebekah also shows trust in God in her willingness to leave her home and loved ones to marry a stranger in a distant land.

Memory Verse: "The LORD delights in those who fear him, who put their hope in his unfailing love."
Psalm 147:11

Questions

Read Genesis 22:1-19 and fill in the blanks.

1. Find the following words in the following matrix

SARAH
BURIED
MACHPELAH
ARAM
NAHARAIM
CHIEF SERVANT
REBEKAH
WELL
NAHOR
HARAN
TWINS
ESAU
JACOB

Q	B	Q	Q	U	U	T	Q	E	S	A	R	Y	T	Q	Q	Q	S
Q	T	U	Q	R	J	H	N	A	H	O	R	H	R	A	R	A	M
C	E	W	R	E	M	G	O	R	Q	Q	O	F	Y	M	R	U	Q
H	S	R	Q	I	E	D	P	E	Q	Q	T	D	U	A	Y	R	R
E	R	F	Q	Q	E	R	U	R	R	W	Y	R	E	C	R	D	S
I	E	G	Q	Q	E	D	Y	H	T	E	Q	D	Q	H	E	T	A
F	S	J	A	C	O	B	A	D	U	L	B	T	Q	P	D	Y	R
S	R	P	E	Q	Q	E	T	K	L	E	E	Q	E	R	N	A	
E	I	E	U	Q	O	E	S	A	U	L	R	L	K	L	Y	H	H
R	O	Z	R	J	E	N	U	O	K	T	B	T	K	A	O	J	D
V	Y	X	E	Q	I	L	R	O	Y	E	Q	A	T	H	H	D	E
A	T	C	Q	T	K	J	R	U	Y	S	H	E	R	T	Q	R	R
N	V	D	T	W	I	N	S	T	E	R	A	R	E	R	O	D	S
T	N	R	P	Y	T	E	R	R	A	A	R	T	B	D	T	T	Y
Y	M	K	R	T	E	D	A	W	U	S	A	S	E	T	R	D	U
T	O	H	T	E	R	E	S	P	R	E	N	T	K	R	P	F	R
E	O	Y	E	R	S	R	E	Q	E	R	Q	T	A	D	A	F	O
R	N	A	H	A	R	A	I	M	J	H	Q	Y	H	U	E	K	P

2. Where did Abraham ask his chief servant to go and find a wife for his son Isaac?

3. Rebekah was the daughter of _____ and the grand-daughter of _____ who was the _____ of Abraham.
4. When the twins were born what unusual thing happened?
5. The twins were named _____ and _____.
6. After she was married, Rebekah became pregnant with twins. The babies struggled with each other even before they were born. When she asked 'why was this happening to me', what answer did the Lord give her?
7. Describe the return of Abraham's chief servant together with Rebekah and her servant and what her arrival must have meant to Isaac.
8. How can this story of God's providing a wife to Isaac be an encouragement to us of God's guidance and loving care?

Application Questions:

1. Why did Abraham insist on payment for the land he acquired as burial ground?
2. What evidence did God give Rebekah that she could trust the servant of Abraham and travel with him such a long distance to Isaac?

Genesis Volume 2

Chapter 14: JACOB AND ESAU

Based on chapter 16 of the multimedia book and DVD-R

Bible Truth: God blesses us with gifts and talents but can take them away if they are not appreciated.

Objective: Learn to value the talents God has given you and use them in ways that please Him.

Bible Reference: Genesis 25:19 – 34, Genesis 27:1-41

Key Lessons:

1. Esau showed a disregard for his birthright, which carries with it the blessing and responsibility of the covenant promises and leadership of God's people. So God raised another leader to take Esau's place.
2. The birthright and its responsibilities had been passed to Jacob. But this causes disharmony in the family because Jacob and his mother Rebekah stole it from Esau. However, God is sovereign and uses the weaknesses of man to bring about His purposes.

Memory Verse:

“A fool finds pleasure in wicked schemes, but a person of understanding delights in wisdom. ”
Proverbs 10:23

Read Genesis 25:19-34 and Genesis 27:1-41

Understanding the Lesson

1. How long did Isaac and Rebekah wait to have children?
2. Each of the key characters in the story made a mistake. But each of them also had strengths. Summarise what were their mistakes/weaknesses and strengths and give your reasons:

	Mistakes/weaknesses	Strengths
a. Isaac		
b. Rebekah		
c. Esau		
d. Jacob		

3. Look up the definition for the word 'birth-right'. What was Esau's attitude towards his birth-right? What does God think of the choices Esau made and what lessons do you learn from Esau?

4. Why do you think Jacob desired the birth-right?

5. What is the difference between regret and repentance? Which describes Isaac and which describes Esau? (Read Gen 27:26-41)

Challenge Question:

From the recorded words and actions of Esau in Genesis 25-27, why do you think Esau proved unworthy to receive the blessing of the first-born?

Application Questions:

1. In what ways can we be tempted to give up long-term benefits in order to gain some immediate satisfaction?

2. Share a time when you have been tempted to sell your 'birth-right' for a quick meal and how you overcame such temptations?

Challenge Application Questions:

Do you think Jacob and Rebekah was right in doing what they did based on what was described in this story? What should Jacob and Rebekah have done instead?

Genesis Volume 2

Chapter 15: JACOB'S JOURNEY AND LABAN'S DAUGHTERS

Based on chapter 17 and 18 in the multimedia book and DVD-R

Bible Truth: Trusting God is like a journey. When we submit to Him, He will mould us into better people. Don't cheat people of what is theirs.

Objective: Learn to build a relationship with God in order to be a stronger Christian. Learn to deal honestly with others. Learn to be patient.

Bible Reference: Genesis 27:42 - 29:12, Genesis 29:13-30:43

Memory Verse: He then added, "Very truly I tell you, you will see 'heaven open, and the angels of God ascending and descending on the Son of Man.'" John 1:51

Key Lessons:

1. Jacob is fleeing from his brother Esau's anger. On the journey, God appears to Jacob for the first time and confirms the Covenant promise made to his forefathers. Jacob prays a prayer with conditions.
2. God begins a process of preparing Jacob to be the leader of His people.
3. Jacob who deceived his father earlier is now deceived by his uncle into many years of service. Despite this, God protects and blesses Jacob. However, Jacob has to work hard and learn patience.



Copyright © Pristine World

Questions

Fill in the blanks.

1. Rebekah said to Jacob, 'Go at once to my brother _____ who lives in _____.'
2. Stay there until _____.
3. Jacob started his journey from _____ and headed towards _____.
4. Along the way when he was sleeping one night he had a dream. In the dream he saw _____ that was standing on the earth but its top reached to _____.

5. _____ were going up and coming down the stairway.
6. Above the stairway stood God who said: "I am the Lord, the God of _____. I will give you and your children after you _____."
7. Jacob made a vow, saying "If _____ will be with me and _____ on this _____ I am taking and will give me _____ and _____ so that I return safely to _____, then the _____ and this stone that I have set up as a pillar will be _____, and of all that you give me, I will give you _____."
8. On seeing _____ he went over and rolled the stone away from the mouth of the well and watered the sheep. He then kissed her and began to _____.
9. Laban had two daughters, _____ and _____.
10. Jacob worked for seven years for right to marry _____. After seven years, on the night of the wedding, Laban gave him _____.
11. Jacob had to work another _____ years for the right to marry _____.
12. Fill in the blanks in Jacob's family tree

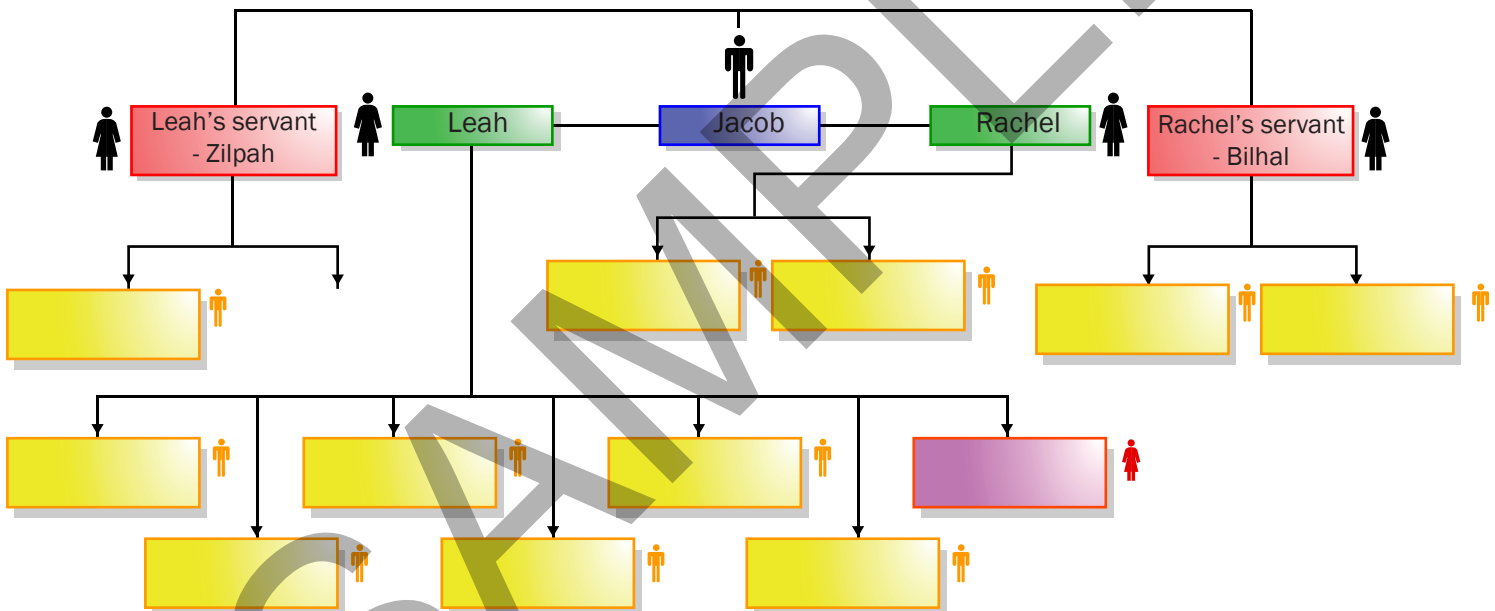

Challenge Question:

1. What did the stairway dream symbolise for Jacob and why did Jesus use it to describe Himself? Read John 1:51 and John 14:6.

2. Why do you think God allowed Laban to deceive and mistreat Jacob? What important lessons of life might Jacob have learnt from this mistreatment?

Application Questions:

1. In what way did Jacob have to trust in God during his journey to Haran, even more than Abraham's servant as described in Genesis 24? What challenges do we face in our journey today and how can we be encouraged by the story of Jacob's Journey?
2. In what way was Jacob a good servant to Laban? What can we learn from Jacob's work attitude?
3. How would you like to have Laban as your boss? In what ways should we not follow Laban's example?

Genesis Volume 2

Chapter 16: JACOB'S RETURN TO CANAAN

Based on chapter 19 in the multimedia book and DVD-R

Bible Truth: Struggles are part of the way God builds us.

Objective: Learn to respond to God's protection and care.

Bible Reference: Genesis 31:1 – 33: 19 & Genesis 35

Key Lessons: Jacob is now prepared to accept the responsibilities that come with the birthright he stole from Esau. Jacob also faces his fears about meeting Esau. All these years God has been preparing Jacob to become Israel's leader. This is shown in Jacob's wrestling with God who gives him the new name of 'Israel'. When God meets him again in Bethel, Jacob worships God unconditionally.

Memory Verse: "The LORD gives strength to his people; the LORD blesses his people with peace."
Psalm 29:11

Questions

Read Genesis 31:1-55

1. Fill in the blanks in the following sentences. Then search for the word in the puzzle.

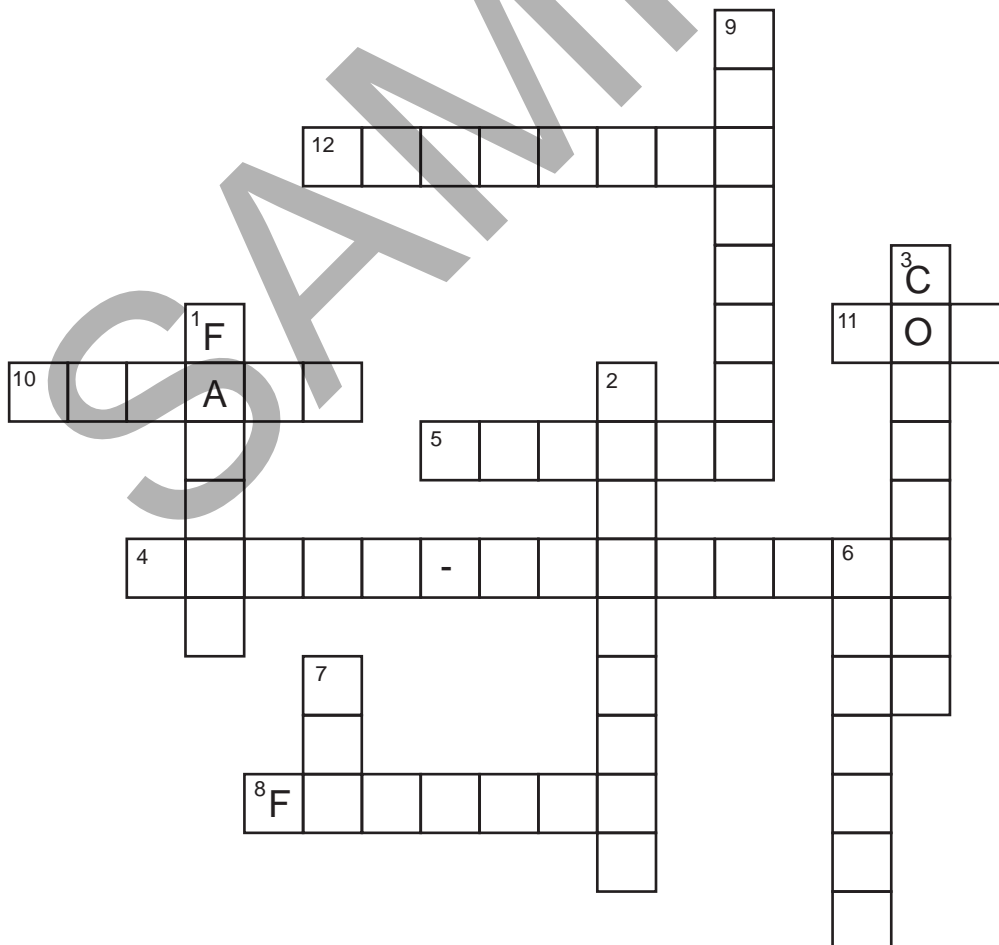

- a. The Lord spoke to Jacob, “Go back to the land of your _____ and your _____. I will be with you.”
(1 down) (2 down)
- b. In Genesis 31:44 Laban said to Jacob, “Come now, let’s make a _____, you and I, and let it serve as a witness between us.”
(3 down)
- c. Jacob and Laban took stones and piled them up. Then they sat down beside the pile of stones to eat a covenant meal. Laban called the place _____ which means ‘witness pile in Aramaic. Jacob called it _____ which means ‘witness pile’ in Hebrew.
(4 cross) (5 cross)
- d. Jacob heard that Esau his brother was coming for him. He sent words of peace, but they returned with the terrifying news that Esau was on the march with four _____ men.
(6 down)
- e. Terrified of Esau, Jacob divided everything he had into _____ large groups and sent them off in different directions.
(7 down)
- f. He sent Esau many gifts hoping that Esau would _____ him.
(8 cross)
- g. The night Jacob was alone and a man _____ with him.
(9 cross)
- h. After a long struggle the man said to Jacob, “Your name will no longer be Jacob, but _____, because you have struggled with _____ and men and have _____.”
(10 cross) (11 cross) (12 cross)
2. Why did Jacob decide it was time to leave Haran and return to Canaan?

3. What do you think was Laban’s intention when he started chasing after Jacob and why do you think he made peace in the end?

4. What do you think was Esau’s intention when he started out to meet Jacob and why do you think he made peace with Jacob in the end?

Genesis Volume 2

Chapter 17: JOSEPH AND HIS BROTHERS

Based on chapter 20 and 21 in the multimedia book and DVD-R

Bible Truth: God's plans can be fulfilled under both good and bad conditions. God gives us the strength to resist temptation.

Objective: Know that God watches over His children at all times. Say 'No' to temptation no matter how attractive it is.

Bible Reference: Genesis 37; Genesis 39:1-20

Key Lessons: Joseph's brothers are jealous of him and sell him off as a slave. However, God has other plans and uses this situation to eventually fulfill His purposes. In spite of his circumstances, Joseph keeps faith with the God of his forefathers. God blesses Joseph in all that he does and his master recognises it. Potiphar's wife tempts him but Joseph flees. He does not want forbidden fruit.

Memory Verse: "He does not take his eyes off the righteous; he enthrones them with kings and exalts them forever." Job 36:7

Make a crossword puzzle

- How old was Joseph at the beginning of this story? _____
(1 Cross)
- Jacob loved _____ more than any of his other children
(2 Cross)
- Jacob gave Joseph a beautiful _____.
(3 down)
- Joseph dreamt that the bound sheaves of the brothers all _____
(4 Cross)
down to his bound sheaves.
- In his second dream, even the _____ and the _____ and
(5 Cross) (6 Down)
eleven stars bowed to his star.
- When the brothers saw this, they became very _____ and hated
(2 Down)
him even more.
- When the brothers wanted to kill Joseph which brother suggested to just throw him into an empty well in the desert? _____
(7 Down)

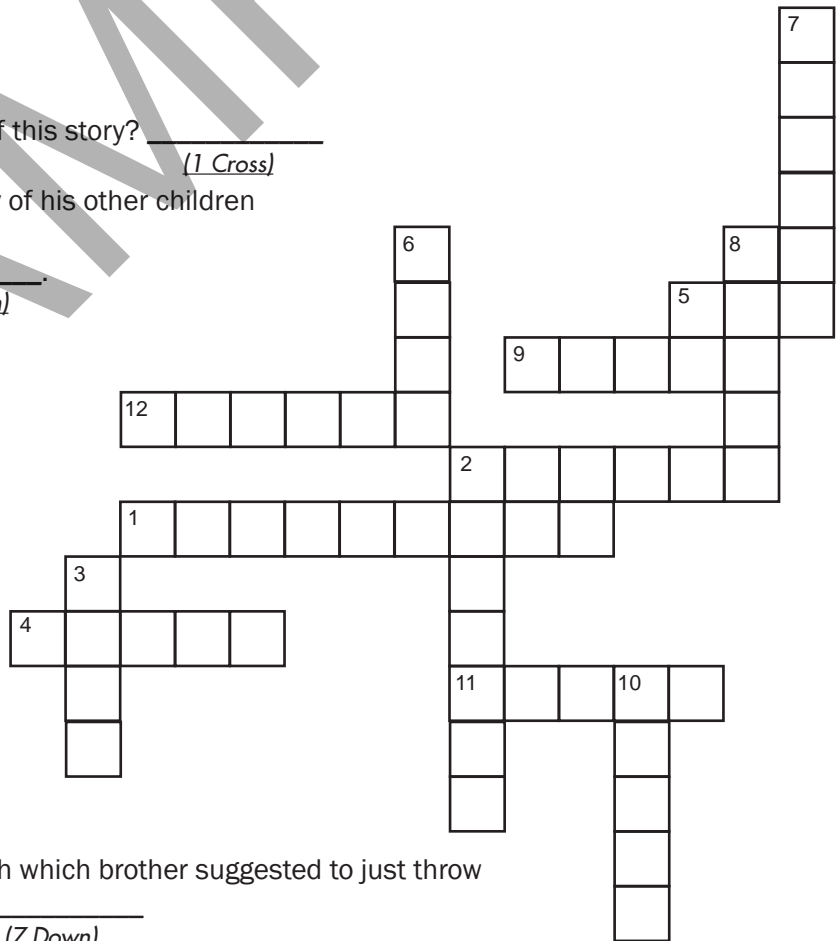

8. Which brother suggested to sell Joseph to the Ishmaelites? _____
(8 Down)
9. The brothers took Joseph's coat and dipped it in animal _____.
(9 Cross)
10. The Ishmaelites took Joseph to _____ and sold him to Potiphar.
(10 Down)
11. God gave Joseph success in Potiphar's house. Potiphar entrusted to Joseph everything that he _____.
(11 Cross)
12. Potiphar's wife caused Joseph to be put into _____.
(12 Cross)

Challenge Questions:

1. Why do you think God gave Joseph the dreams mentioned in Genesis 37:1-11?
2. Why do you think Potiphar trusted Joseph so much?

Application Questions:

1. What can we learn from this story about the times when we face unexpected problems or when we are mistreated by family members or friends or others? Can you see any positive outcomes to any difficult situations you are facing now?
2. Joseph is living as a slave far from his country of origin, yet he keeps his faith and worships the God of his fathers. He is a fine example in the way he works for his master. What can we learn from Joseph's example in the way that he carries out his responsibilities and keeps his faith in God?

Challenge Application Questions:

In these two stories, how do you think God was using the situation to train Joseph for future leadership?

Genesis Volume 2

Chapter 18: THE PRISONER AND THE KING

Based on chapter 22 and 23 in the multimedia book and DVD-R

Bible Truth: God allows bad things to happen but He never leaves His children. Wisdom is from God.

Objective: To do our best even in bad situations. Learn to seek God for wisdom and not rely on our own understanding.

Bible Reference: Genesis 39: 21 - 40: 23; Genesis 41:1 - 46

Key Lessons: Instead of moaning about how he had been wrongfully punished, Joseph works hard and impresses the people around him. Even the prison warden trusts him. Joseph continues to trust in God who watches over him and prepares him for an important task ahead. Despite helping the cupbearer, Joseph is forgotten and left in prison. He still has to be patient. He then interprets Pharaoh's dream correctly. Finally, after 13 years of slavery and imprisonment, Joseph is made Pharaoh's most senior minister.

Memory Verse: "For it is commendable if someone bears up under the pain of unjust suffering because they are conscious of God." 1 Peter 2:19

Questions:

1. How did the prison warden view Joseph?
2. What did the prison warden do for Joseph?
3. Who were two officials put into the same prison as Joseph?
4. Describe the two dreams that Pharaoh had

5. Why did God give Pharaoh two dreams?

6. What was the meaning of the dreams?

7. Who did Joseph say has revealed the meaning of the dreams?

8. Who did Pharaoh give Joseph as a wife?

9. How old was Joseph when he entered the service of Pharaoh?

10. Look for the following words in the word puzzle:

GRAPES
 PHARAOH
 CUPBEARER
 BAKER
 SEVEN
 FAT
 COWS
 GRAIN
 ASENATH
 ZAPHENATH
 PANEAH

R	P	Q	Y	E	A	S	E	E	K	Y	K	K	T	C	J
T	E	H	Q	K	J	E	R	R	Y	R	N	Y	O	U	T
E	T	B	A	K	E	R	T	T	T	D	Y	U	I	P	Y
W	E	Q	E	R	Q	Q	S	S	R	T	R	Y	Y	B	R
E	S	H	Q	F	A	T	O	T	S	Y	F	T	C	E	E
R	T	A	W	Q	Q	O	Q	T	A	O	R	R	S	A	D
Y	Y	M	N	U	E	Q	H	R	E	E	D	E	R	R	S
R	P	A	N	E	A	H	K	D	S	W	T	H	Z	E	S
I	Q	Q	Q	Q	E	M	Y	Y	S	T	P	A	R	R	
I	G	R	A	I	N	T	B	D	R	A	K	R	P	U	E
O	A	Q	Q	E	H	G	F	R	N	H	N	Y	H	R	G
G	E	Q	V	T	M	F	C	E	U	T	M	D	E	T	R
F	I	E	U	Y	C	D	S	E	R	R	R	A	N	E	A
R	S	Q	O	U	V	A	R	R	O	D	D	D	A	S	P
H	H	Q	F	E	D	Q	T	Y	P	Y	T	R	T	E	E
R	G	C	O	W	S	Q	A	S	P	A	R	D	H	O	S

Challenge Questions:

1. What do you think was Joseph's greatest disappointment while in prison?

2. Give four main points in Joseph's interpretation of Pharaoh's dream (Gen 41:25-32). What five things did Joseph tell Pharaoh to do? (Read Gen 41:33-36)
3. How did Pharaoh honour Joseph and raise him to a highly exalted position?

Application Questions:

1. How do we know that God was watching over Joseph through all his difficult circumstances? What can we learn from this when we are going through difficulties?
2. List the characteristics of Joseph which have been consistently shown since Joseph's childhood till the time he was brought before Pharaoh. List some changes in his behaviour since his childhood with his family in Canaan. What can we learn from Joseph?

Challenge Application Questions:

1. Share some lessons you have learned in the past few years which have brought about positive changes in your attitude and reaction to other people. What did you learn that helped you make those changes?

Genesis Volume 2

Chapter 19: FAMILY CONFRONTATIONS

Based on chapter 24 and 25 in the multimedia book and DVD-R

Bible Truth: Although we are to trust God, the Bible also recognises hard work as important. Be a responsible and reliable person.

Objective:

1. Be hardworking in life for this brings God glory.
2. Even when we are successful, we must still forgive others.

Bible Reference: Genesis 41:47 - 42:26; Genesis 42:27 - 44:13

Memory Verse: "All hard work brings a profit, but mere talk leads only to poverty." Proverbs 14:23



Key Lessons:

1. Joseph worked hard to prepare Egypt for the famine. Egypt was blessed because of Joseph and this is noticed by Pharaoh.
2. When Joseph meets his brothers, they do not show any outward remorse. Joseph decides not to reveal himself to them but tests them first.
3. Reuben makes a rash promise about Benjamin. Jacob does not trust Reuben to take care of Benjamin, because Reuben has disappointed him before. But he trusts Judah.

Questions:

Genesis 41:47 - 42:26

1. What did Joseph do to help Egypt prepare for the approaching famine?

2. What intention for his brothers' good did Joseph have when he did the following:
 - a. He was harsh and accused them of being spies?

- b. He put them in prison for three days?

 - c. He then kept Simeon in prison when he released the others?

 - d. He required Benjamin's presence on their return?

 - e. He put money in their sacks?
3. What clue did Joseph give them that he would treat them fairly?

Genesis 42:27 – 44:13

- 4. Give reasons why you think Jacob did not trust Reuben even though he was the eldest son?

- 5. Give reasons why you think Jacob accepted Judah's word?

- 6. Why was Jacob reluctant to send Benjamin with the brothers to buy food from Egypt?

- 7. What clue did Joseph give his brothers that he knew something more about their family than ordinary? Why do you think he did it?

Challenge Questions:

1. Why did Joseph give his brothers a big meal? What do you think was his purpose to serve Benjamin five times more food during this meal? What good would that have done to his brothers?

2. What was his purpose of putting his own silver goblet into Benjamin's sack?

Application Questions:

1. Imagine you are one of the brothers and you have realised that something you have done in the past was terribly wrong. What would you have done?

2. Imagine you were Joseph in this story. What would you do? What can you do for people who have wronged you in the past? What can we learn from Joseph's actions?

Challenge Application Questions:

1. Look at Reuben's actions. Based on what he did and said, what can we learn from his mistakes and how can we avoid similar actions or words?

2. Look at Judah's actions. What can we learn from what he did and said?

Genesis Volume 2

Chapter 20: FAMILY RECONCILIATION

Based on chapter 26 in the multimedia book and DVD-R

Bible Truth: Peace and unity comes with forgiveness.

Objective: To forgive family members who hurt us.

Bible Reference: Genesis 44: 14 - 46: 7

Key Lessons:

1. The brothers refuse to leave Benjamin even at the expense of their own freedom. Joseph sees this as their repentance for their past action against him, and reveals himself.
2. Joseph knows that God has used this situation to save his family from the famine and to re-unite them in Egypt.

Memory Verse: "If we confess our sins, he is faithful and just and will forgive us our sins and purify us from all unrighteousness." 1 John 1:9

Read Genesis 44:14 – 46:7

Understanding the Lesson

1. Why had Joseph shown extra favour and kindness to Benjamin? And why was he picking on Benjamin as the main culprit now?
2. What were some of the signs which showed that the brothers may have changed in character from the time when they had sold Joseph off as a slave?
3. Why was Joseph not satisfied with these signs?

4. What further test did Joseph put to his brothers?

5. Why did Judah's answer convince Joseph that his brothers had repented from the past?

6. How did Joseph show them that he had forgiven them?

7. How did Pharaoh show great respect and honour towards Joseph and why do you think he did this?

8. Why did Jacob stop at Beersheba and to offer sacrifices and pray? What message did he receive from God?

Application Questions:

1. What can we learn from Judah's actions in this story? What some good characteristics shown by Judah that we can emulate today?

2. How did Joseph give all the credit and glory to God? What can we learn from his character and how can we apply it today?

c. Jacob:

d. Joseph:

3. What is the most significant lesson you have learned from the study of Genesis and how can you apply it in your life?

Challenge Question:

Which stories in Genesis paint a picture of Jesus and what He would do later?

SAMPLE

The Visual Bible Explorer Series

Multimedia Books Currently Available

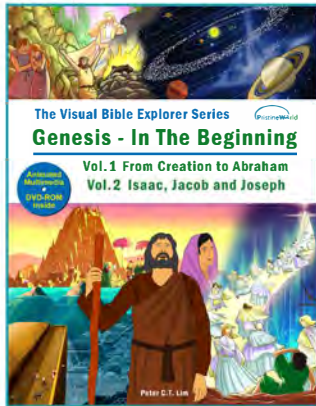

Genesis - In The Beginning

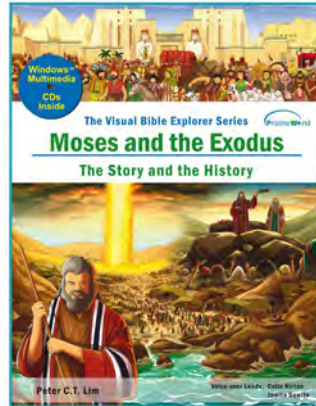

Moses and the Exodus

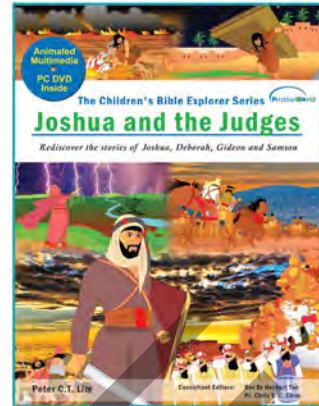

Joshua and the Judges

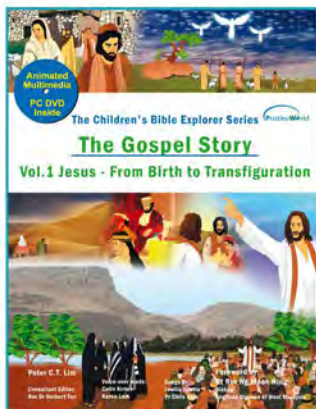

The Gospel Story Vol. 1

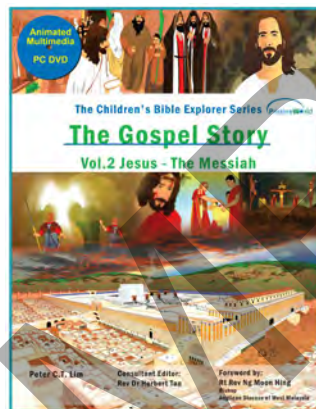

The Gospel Story Vol. 2

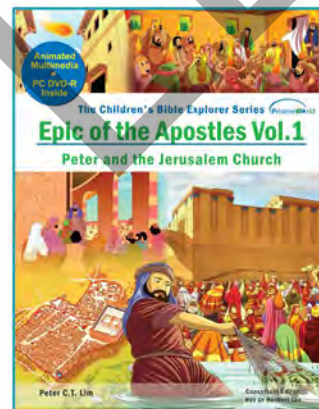

Epic of the Apostles Vol. 1

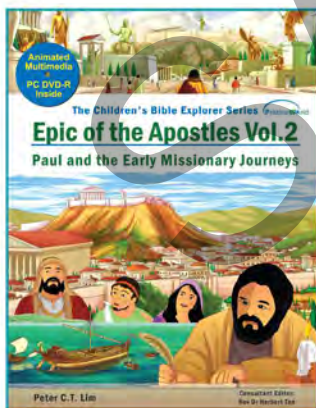

Epic of the Apostles Vol. 2



Visit us at www.pristine-world.com
For inquiries e-mail us at pristineworld@gmail.com

Pristine World Sdn Bhd
All Rights Reserved 2018