

Student Workbook for The Visual Bible Explorer Series



The Gospel Story

Vol.1: Jesus - From Birth to Transfiguration

Vol.2: Jesus - The Messiah

Primary School Level 1

Ages 7 - 8

SAMPLE

Student Workbook for
The Visual Bible Explorer Series

The Gospel Story

Vol. 1: Jesus - From Birth to
Transfiguration

Vol. 2: Jesus - The Messiah

Ages 7 - 8

Copyrights



First published in Malaysia in 2010 by Pristine World Sdn Bhd
Copyright © 2010, 2018, 2023 Pristine World Sdn Bhd, Malaysia

All rights reserved. No part of this publication or multimedia may be reproduced, stored in a retrieval system or transmitted in any form or by any means, electronic, mechanical, photocopying, recording, scanning or otherwise, without the prior written permission of the copyright owner.

Scripture taken from the **HOLY BIBLE, THE GOOD NEWS BIBLE**® . Copyright © 1973, 1978, 1984 by International Bible Society. Used by permission of Zondervan Publishing House. All rights reserved.

The “NIV” and “New International Version” trademarks are registered in the United States Patent and Trademark Office by International Bible Society. Use of either trademark requires the written permission of International Bible Society.

Acknowledgements

Pristine World would like to say thank you to Goh Kim Guat, Lydia Wong Hwei Ming, Chew Bee Bee and Samantha Yong for taking time out to help develop the Student Workbooks for this series.

Summary Chart of Christ's Ministry

Event	Place	Date (approx)
1. Birth of Jesus	Bethlehem	4 -6 BC
2. Baptism of Jesus	Jordan River	26 AD
3. Jesus is tempted by the Devil	Wilderness	26 AD
4. Jesus calls his first disciples	Capernaum Sea of Galilee	27 AD
5. Jesus selects the 12 disciples	Capernaum	28 AD
6. The Sermon on the Mount	Galilee	28 AD
7. Jesus calms the storm and heals Jairus's daughter	Sea of Galilee Capernaum	28 AD
8. 12 disciples sent out to preach and to heal	Capernaum	28 AD
9. Herod Antipas murders John the Baptist	Machaerus	29 AD
10. Jesus feeds the multitude and then walks on water	Near Bethsaida Sea of Galilee	29 AD 29 AD
11. Peter says that Jesus is the Son of God	Caesarea Philippi	29 AD
12. Jesus is transfigured	Mountain top	One week later
13. Jesus raises Lazarus from the dead	Bethany	Late 29 AD
14. Jesus begins His last trip to Jerusalem	Bethany	30 AD
15. Jesus meets with Zacchaeus	Jericho	30 AD
16. Jesus enters Jerusalem and spends the final week there	Jerusalem	30 AD Sunday to Thursday
17. Crucifixion	Jerusalem	Friday
18. Resurrection	Jerusalem	Sunday
19. Jesus appears to ten disciples	Jerusalem	Sunday
20. Jesus appears to the eleven disciples (including Thomas)	Jerusalem	One week later
21. Jesus talks with some disciples	Sea of Galilee	
22. Jesus ascends to Heaven	Mt. of Olives, Jerusalem	40 days later

* Dates are approximated up to + or - 2 years

The Gospel Story Vol. 1

CONTENTS

Lesson 1	The Birth of John the Baptist Foretold	6
Lesson 2	The Birth of Jesus Foretold	8
Lesson 3	The Birth of Jesus	10
Lesson 4	The Magi and the Star	12
Lesson 5	John the Baptist	14
Lesson 6	The Temptation of Jesus	16
Lesson 7	I Will Make You Fishers of Men	18
Lesson 8	The Calling of the 12 Disciples	20
Lesson 9	The Power to Heal and Forgive Sins	22
Lesson 10	The Authority to Forgive Sins	24
Lesson 11	The Beatitudes	26
Lesson 12	The Sermon on the Mount	28
Lesson 13	Faith, Power and Authority	30
Lesson 14	Jesus and Jairus' Daughter	32
Lesson 15	Feeding the Great Crowd	34
Lesson 16	Peter Proclaims Jesus the Messiah	36
Lesson 17	The Transfiguration	38

The Gospel Story Vol. 2

CONTENTS

Lesson 18	The Samaritan Woman And The Good Samaritan	40
Lesson 19	The Importance Of Being Humble	42
Lesson 20	Parables Of The Lost And Found	44
Lesson 21	Jesus And Lazarus	46
Lesson 22	Jesus And Zacchaeus	48
Lesson 23	Jesus Enters Jerusalem	50
Lesson 24	Jesus And Nicodemus	52
Lesson 25	The Lord's Supper	54
Lesson 26	The Passover Meal And Its Meaning	56
Lesson 27	The Garden Of Gethsemane	58
Lesson 28	Jesus Is Tried By The Jews	60
Lesson 29	Jesus Stands Before Pilate	62
Lesson 30	The Crucifixion	64
Lesson 31	The Hour After The Crucifixion	66
Lesson 32	The Resurrection	68
Lesson 33	The Last Breakfast	70
Lesson 34	The Great Commission	72
	Notes	74

The Gospel Story Vol. 1

Lesson 1: INTRODUCTION TO THE GOSPEL STORY AND THE BIRTH OF JOHN THE BAPTIST FORETOLD

Theme: God chose John.

Lesson Aim: That the children will thank God that He has chosen them even before they were born and has a special purpose for their lives.

Bible Reference:
Luke 1:5-25, 57-80

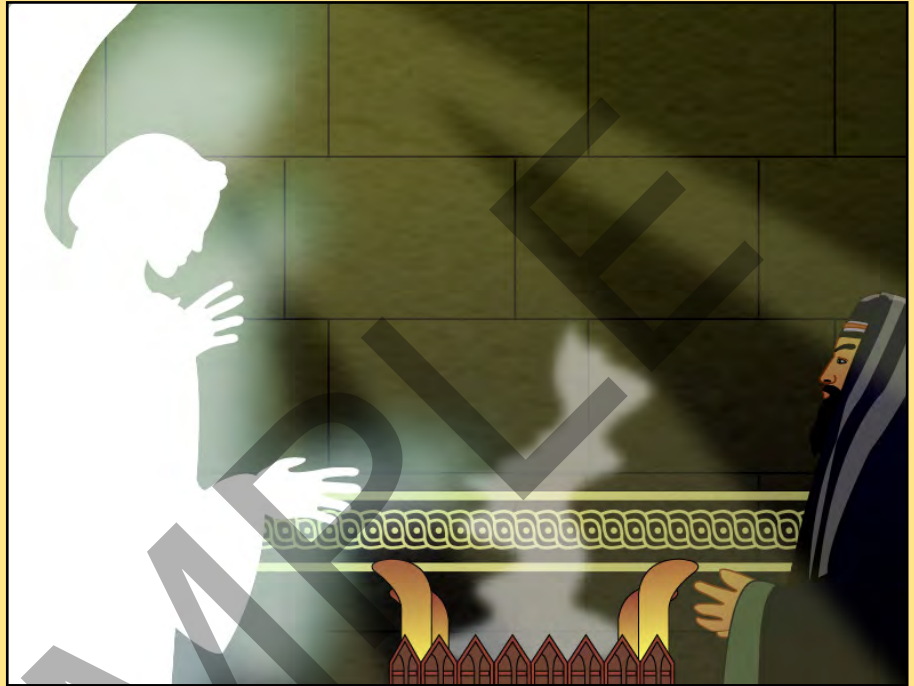

Learn

Bible Truth

1. Getting to know the characters of the gospel.
2. John's mission was to prepare the way for the Messiah.

Memory verse

“For I know the plans I have for you,” declares the Lord, “plans to prosper you and not to harm you, plans to give you hope and a future.”

Jeremiah 29:11

Discover

Fill in the Blanks

1. Herod was the _____ of Judea.
2. Zechariah's wife was _____.
3. They had _____ children.

Colour it

Find out who appeared to Zechariah.

Discover it Circle the correct answer.

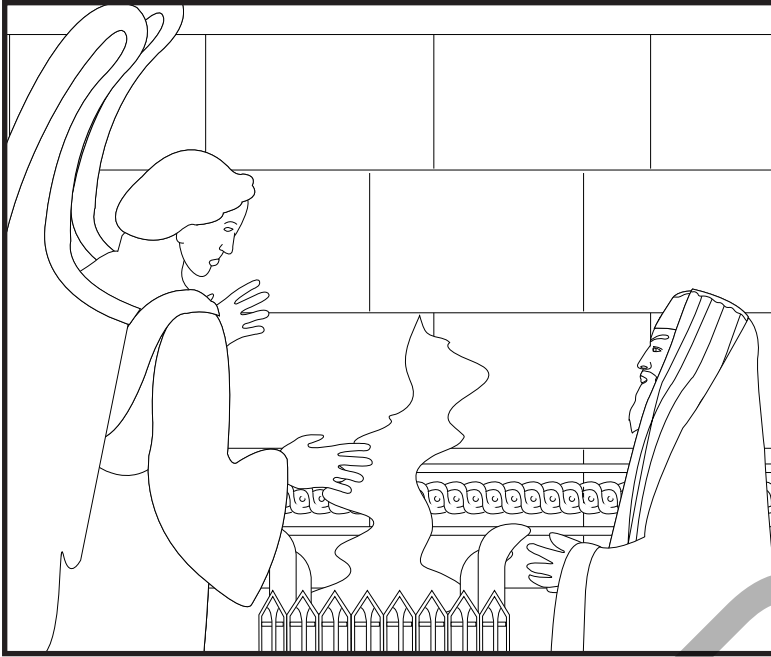

1. Is it true that Zechariah was a priest in Judea?

(True / False)

2. Is it true that Zechariah and Elizabeth did not have children?

(Yes / False)

Fill in the blanks

1. The angel said that John will be a g _ _ _ t man .
2. John was not allowed to drink w _ n _ .
3. John will be filled with the H _ _ _ y S _ _ _ _ t.

Respond

What can we learn about God in this story?

Prayer

Dear God, help me to trust in you always. In Jesus' name, Amen.

The Gospel Story Vol. 1

Lesson 2: THE BIRTH OF JESUS FORETOLD

Theme: We can trust that God will fulfill His promises to us.

Lesson Aim: That the children will trust that God is faithful and will always keep His promises to them.

Bible Reference:
Luke 1: 26-56;
Matthew 1:18-25



Learn

Bible Truth

1. God chose a virgin from a poor family to give birth to His Son.
2. Mary believed in the angel and submitted to God's plans.

Memory verse

“I am the Lord’s servant,”
Mary answered. “May it be
to me as you have said.”

Luke 1:38

Discover

Fill in the Blanks

1. God sent the angel, G __ briel to Nazareth.
2. Mary was afr __ id.
3. Mary said: “I am the Lord’s servan __.”

Find the way

Lead Mary on her way to stay with her cousin, Elizabeth.

Yes or No?

Circle the correct answer

1. God chose Mary to give birth to Jesus.

Yes / No

2. Elizabeth named her son Jesus.

Yes / No

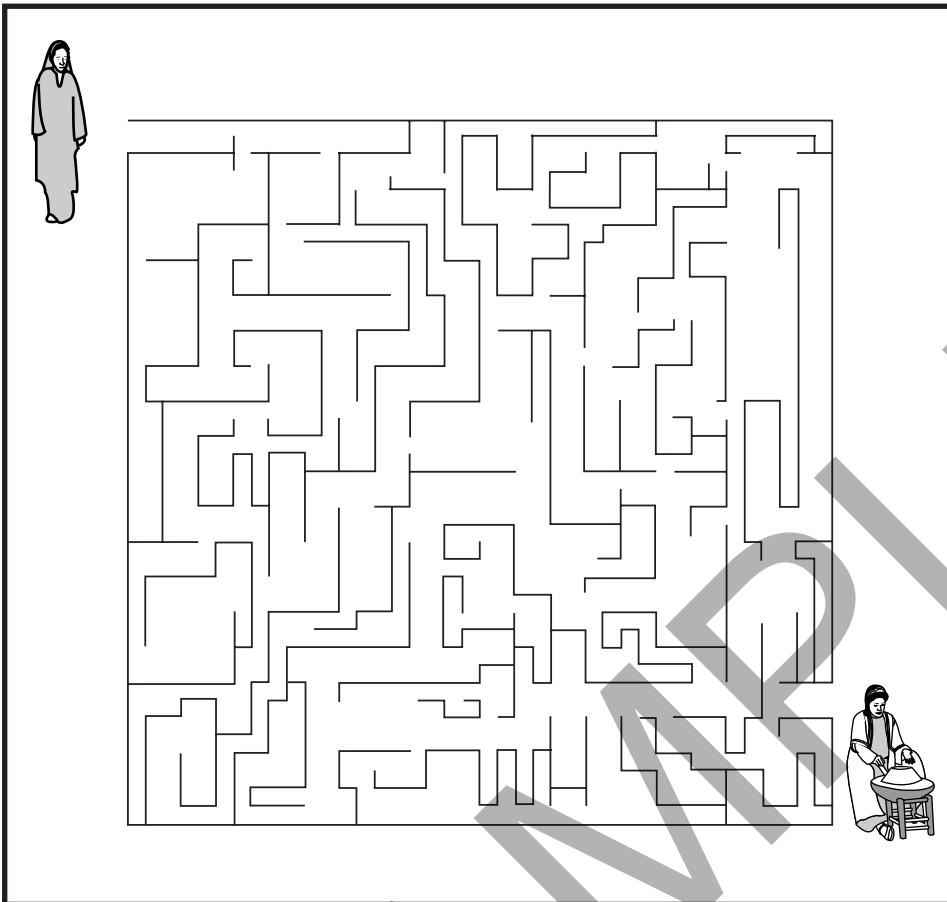

Respond

What can we learn from Mary in this story?

Prayer

Dear God, please help me to obey Your commands. In Jesus' name, Amen.

The Gospel Story Vol. 1

Lesson 3: THE BIRTH OF JESUS

Theme: Jesus is born.

Lesson Aim: That the children will choose to obey God at all times.

Bible Reference:

Luke 2:1-20

Matthew 1:18-25



Learn

Bible Truth

1. Joseph obeyed God and married Mary.
2. God chose shepherds to be the first to hear about the birth of Jesus.

Memory verse

So when Joseph woke up, he married Mary as the angel of the Lord had told him to do.

Matthew 1:24

Discover

Fill in the Blanks

1. Mary and Joseph travelled to _____.
2. There was no room in the _____ for them.
3. Mary laid Jesus in a _____.

Colour it

An army of angels appeared to the shepherds.

19 15 23 8 5 14 10 15 19 5 16 8 23 15 11 5
21 16 8 5 13 1 18 18 9 5 4 13 1 18 25 1 19
20 8 5 1 14 7 5 12 15 6 20 8 5 12 15 18 4
8 1 4 20 15 12 4 8 9 13 20 15 4 15

Matt. 1:24

A= 1 D= 4 G= 7 J= 10 M= 13 P= 16 S= 19 V= 22 Y= 25
B= 2 E= 5 H= 8 K= 11 N= 14 Q= 17 T= 20 W= 23 Z= 26
C= 3 F= 6 I= 9 L= 12 O= 15 R= 18 U= 21 X= 24

Quiz Choose the correct answer.

Engagement afraid

1. Joseph wanted to break his _____ with Mary.
2. The angel told Joseph "Do not be _____ to take Mary as your wife"

Respond

What can we learn about Joseph's character?

Prayer

Dear God, help me to be obedient to You. In Jesus' name, Amen.

The Gospel Story Vol. 1

Lesson 4: THE MAGI AND THE STAR

Theme: God is our protector.

Lesson Aim: Know that God deserves to be worshipped

Bible Reference:
Matthew 2:1-23;
Luke 1:46-56; 2:8-20



Learn

Bible Truth

1. Jesus was born in a manger in Bethlehem.
2. He will be worshipped by everyone.
3. God protected Joseph and his family.

Memory verse

“Because he loves Me,” says the Lord, “I will rescue him; I will protect him, for he acknowledges My name.”

Psalm 91:14

Discover

Fill in the Blanks

1. The M __ gi had seen a sign in the stars.
2. They followed the st __ r to Jerusalem.
3. Herod wanted to kill all b __ ys below two years old.
4. God told Joseph to flee to __ gypt.

Photostat, colour and cut.

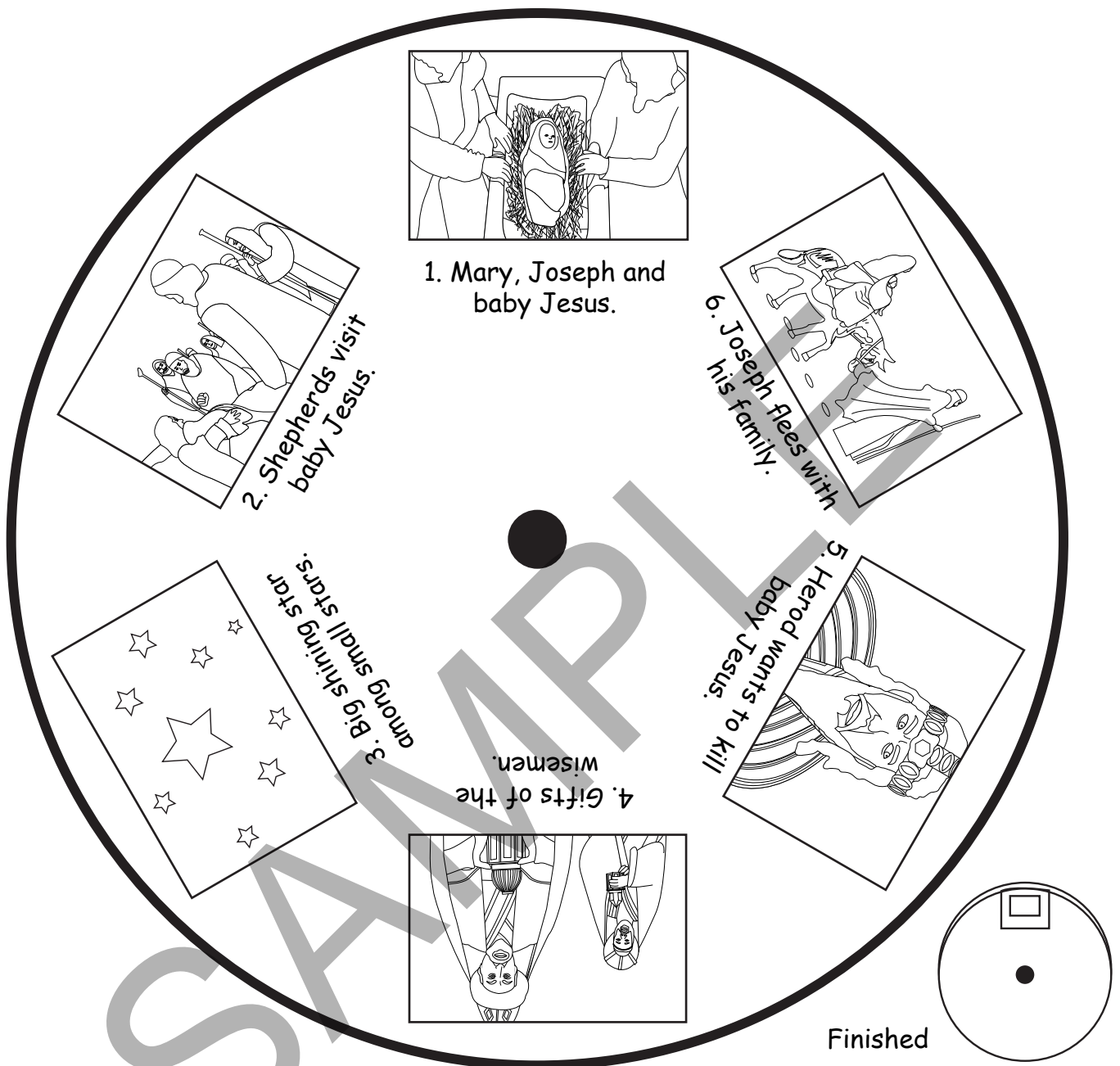

Respond

Why did the Magi want to worship Jesus?

Prayer

Dear God, you are the only one I want to worship. In Jesus' name, Amen.

The Gospel Story Vol. 1

Lesson 5: JOHN THE BAPTIST

Theme: Baptism.

Lesson Aim: Jesus was obedient to God's will.

Bible Reference:

Luke 3:1-22

Matthew 3:1-17



Learn

Bible Truth

1. John preached the message of repentance and proclaimed the coming of Jesus.
2. Jesus was obedient to God and was baptised.

Memory verse

“Although he was a son, he learned obedience from what he suffered.”

Hebrews 5:8

The right picture? Circle the correct picture.

1. John preached the message of re _____ to everyone.
2. John baptised believers in the J _____ n River.
3. John baptised J _____.

Decode it

Find out what the voice from heaven said.

“
20 8 9 19 9 19 15 25
15 23 14 4 5 1 18 19 15 19
23 9 20 8 23 8 15 13 9
1 13 16 12 5 1 19 5 4

Matthew 3:17

A= 1 D= 4 G= 7 J= 10 M= 13 P= 16 S= 19 V= 22 y= 25
B= 2 E= 5 H= 8 K= 11 N= 14 Q= 17 T= 20 W= 23 Z= 26
C= 3 F= 6 I= 9 L= 12 O= 15 R= 18 U= 21 X= 24

True/False Circle the correct answer.

1. John said that every tree that does not bear good fruit will be cut down and thrown into the fire. (True / False)
2. John baptised people with fire. (True / False)

Prayer

Dear God, help me to obey your will for me. In Jesus' name, Amen.

The Gospel Story Vol. 1

Lesson 6: THE TEMPTATION OF JESUS

Theme: God's word provides us with strength.

Lesson Aim: The Bible gives us strength to obey God.

Bible Reference:
Matthew 4:1-11



Learn

Bible Truth

Like Jesus, we are to know God's Word and be able to use it to help us when we face temptations.

Memory verse

Jesus answered, "It is written: 'Man does not live on bread alone, but on every word that comes from the mouth of God.'"

Matthew 4:4

Discover

Fill in the Blanks

1. Jesus fasted and prayed for 4__ days and nights.
2. Jesus was hun __ ry.
3. The devil told Jesus to turn the stone into b __ __ __ d.

Decode it

Find out what Jesus said to the devil.

"iWroshp teh rLdo royu oGd adn
esver noyl iHm!"

Matt. 4:10

True or False? Circle the correct answer.

- | | |
|--|----------|
| 1. Jesus worshipped the devil. | Yes / No |
| 2. Jesus used scriptures to rebuke the devil | Yes / No |
| 3. Jesus was tempted several times. | Yes / No |
| 4. Jesus performed miracles for his own benefit | Yes / No |
| 5. After the devil left angels came and helped Jesus | Yes / No |

Respond

What can we learn about Jesus from this story?

Prayer

Dear God, please help me to obey you always and give me strength to resist temptation. In Jesus' name, Amen.

The Gospel Story Vol. 1

Lesson 7: I WILL MAKE YOU FISHERS OF MEN

Theme: Be willing to follow God.

Lesson Aim: To learn that God looks at our heart and not our abilities as we obey God.

Bible Reference:
Luke 5:1-11, 27-32
Matthew 10:2-4



Learn

Bible Truth

It is not our gifts or talents but our willingness to follow Jesus that qualifies us to be His disciples.

Memory verse

“The Lord does not look at the things man looks at. Man looks at the outward appearance, but the Lord looks at the heart.”

1 Samuel 16:7b

Discover

Fill in the Blanks

1. Simon, Andrew, James and John were f _____ n.
2. Matthew was a tax C _____ .
3. Jesus told Peter than He will make them F _____ of M _____.

Draw and colour

Draw fishes in the net.

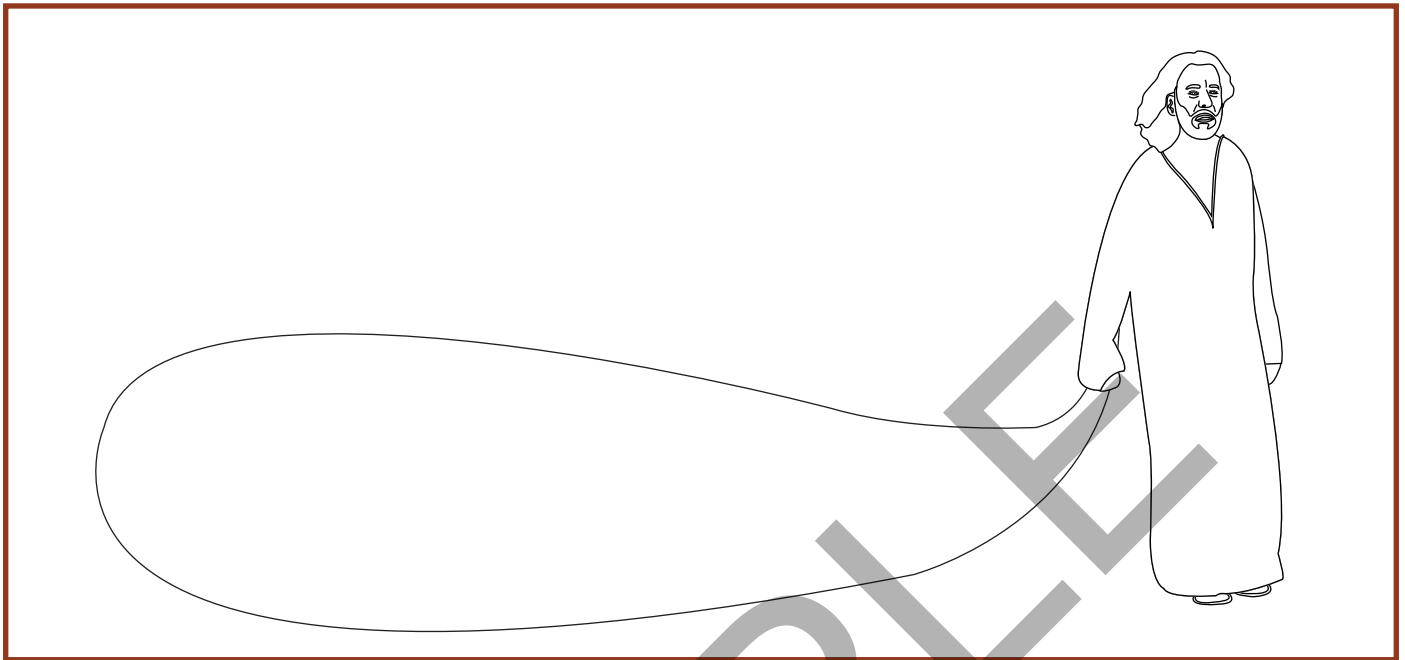

True or False? Circle the correct answer.

1. Peter worked all day and night but was still not able to catch any fish. Yes / No
2. Peter did not listen to what Jesus said. Yes / No
3. The Pharisees were happy that Jesus was having dinner with sinners. Yes / No

Respond

What can we learn about the disciples from this story?

Prayer

Dear God, help me to be willing to follow Jesus. In Jesus' name, Amen.

The Gospel Story Vol. 1

Lesson 8: THE CALLING OF THE 12 DISCIPLES

Theme: To learn to pray.

Lesson Aim: That the children will make prayer a priority in their lives.

Bible Reference:
John 1:43-51;
Luke 6:12-16



Learn

Bible Truth

Jesus prays before He picks His twelve disciples. They will learn from Him, and later on, be His key agents in the founding of His church.

Memory verse

“Do not be anxious about anything, but in everything, by prayer and petition, with thanksgiving, present your requests to God. And the peace of God which transcends all understanding, will guard your hearts and your minds in Christ Jesus.”

Philippians 4:6-7

Discover

Fill in the Blanks

1. Jesus chose ___ disciples.
2. The disciples were to become
| ___ ___ ___ ___ s of the early church.

Do you know?

Prayer is like talking with God on an imaginary phone. The phone line is 24/7 available anywhere.

Why do we need to pray to God?

Below are some teachings from the Bible about praying to God. Write the letter that comes AFTER each letter.

Example (Matthew 7:7-12) GOD TOLD US TO ASK HIM.
FNC SNKCR TR SN ZRJ GHL

1. (Luke 11:1-4) IDRTR ZKRN OQZ XDC SN FNC

2. (Phi 4:7) PRAYER FHUDR TR ODZBD NE FNC

3. (1 Tim 2:1-4) PRAYER HR SN SGZMJ FNC

4. (Luke 11:4) PRAYER HR ZRJHMF ENQ FNC RENQFHUDMDRR

A B C D E F G H I J K L M N O P Q R S T U V W X Y Z

*Note: 'A' comes after 'Z'

Respond

Why did Jesus pray before choosing his disciples?

Prayer

Dear God, teach me to seek You in all I do. In Jesus' name, Amen.

The Gospel Story Vol. 1

Lesson 9: THE POWER TO HEAL AND FORGIVE SINS

Theme: To learn compassion.

Lesson Aim: To be compassionate to those who are rejected by others.

Bible Reference:
Matthew 4:23-25,
Luke 5:12-16



Learn

Bible Truth

Jesus travels all over Galilee, teaching and healing. He heals a leper.

Memory verse

“Therefore, as God’s chosen people, holy and dearly loved, clothe yourselves with compassion, kindness, humility, gentleness and patience.”

Colossians 3:12

Discover

Fill in the Blanks

1. Jesus was t_____g and h_____g around Galilee.
2. Lepers were considered un_____.
3. The leper believed that Jesus had the power to h__l.

Find a way

Help the leper to find his way to Jesus.

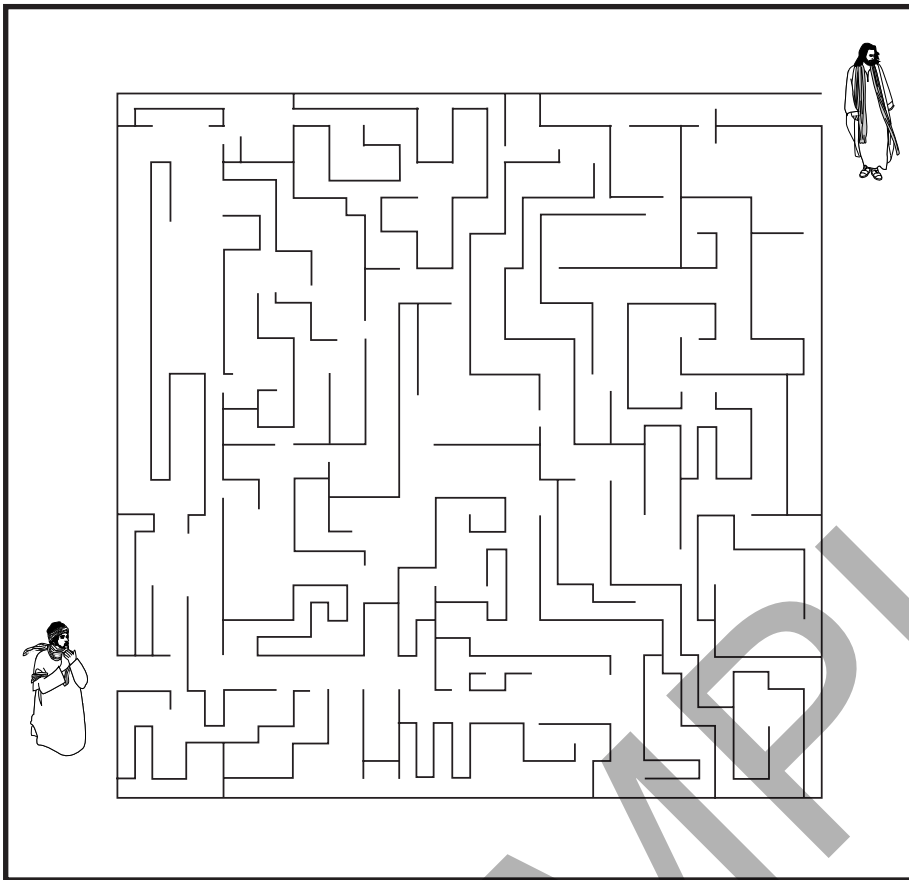

True/False Circle the correct answer

1. Jesus had compassion and healed the man who had leprosy.

(True / False)

2. The man's skin was fresh and new.

(True / False)

3. Jesus said "Go tell everyone what has happened."

(True / False)

Respond

How do we show compassion to others around us?

Prayer

Dear God, teach me to love all my friends and everyone around me. In Jesus' name, Amen.

The Gospel Story Vol. 1

Lesson 10: THE AUTHORITY TO FORGIVE SINS

Theme: Jesus forgives.

Lesson Aim: To know that Jesus will forgive our sins if we are sorry for what we have done.

Bible Reference:
Mark 2:1-12



Learn

Bible Truth

Jesus shows His authority by healing a paralysed man.

Memory verse

“If we confess our sins, he is faithful and just and will forgive us our sins and purify us from all unrighteousness.”

1 John 1:9

Discover

Fill in the Blanks

1. Many people came to see J_____.
2. Four men carried a p_____ man.
3. The te_____ of the l_____ did not like what Jesus said and did.

Photostat, colour and cut. Make a house.

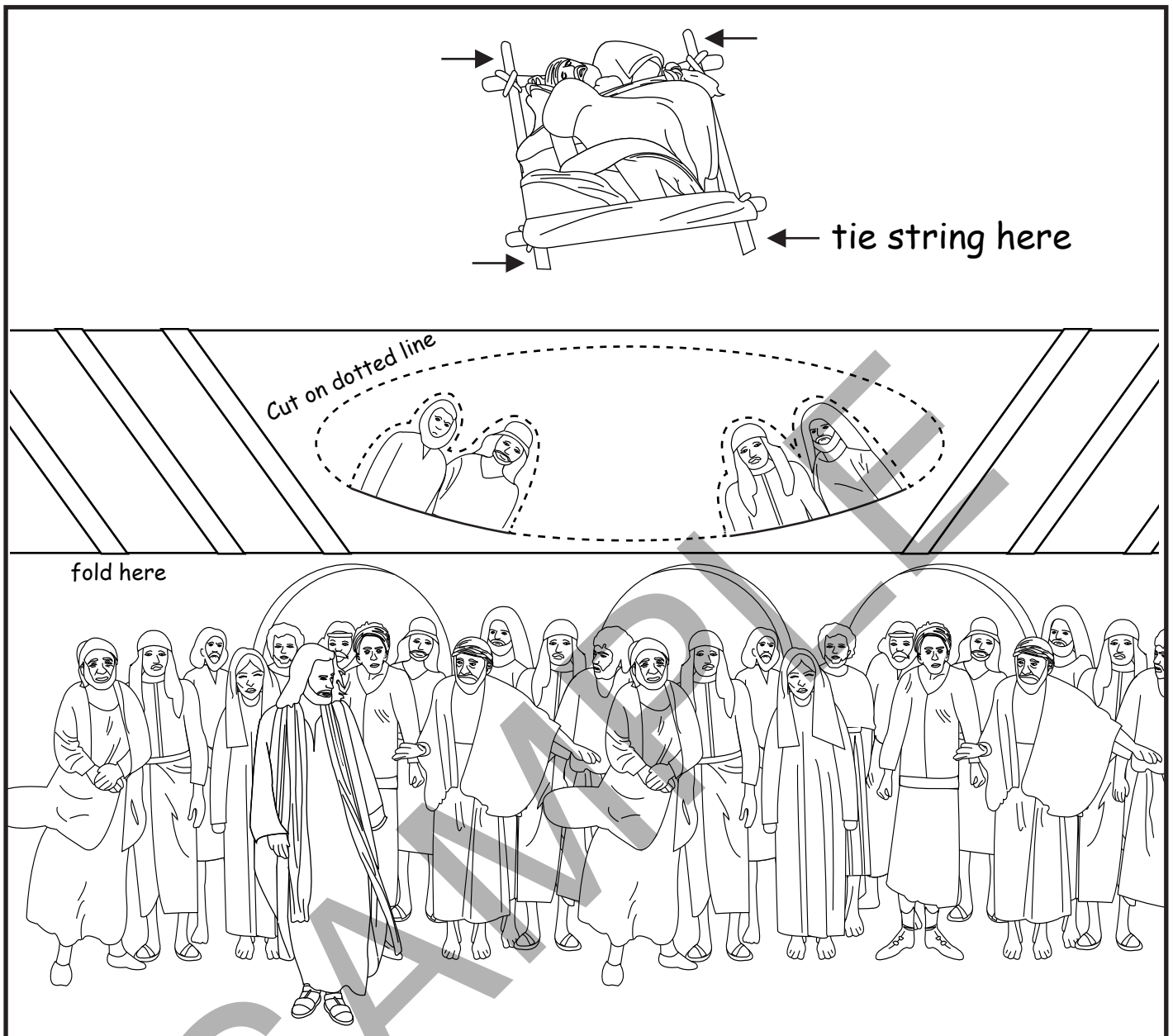

Respond

1. What can we learn from the four friends of the paralyzed man?

2. Will Jesus forgive us when we have done wrong?

Prayer

Dear God, I am sorry for all the wrong things I have done In Jesus' name, Amen.

The Gospel Story Vol. 1

Lesson 11: BEATITUDES

Theme: The right way to live.

Lesson Aim: That the children will be encouraged to know that they are blessed as they do what is right in God's eyes.

Bible Reference:
Matthew 5:3-12,
17-48



Learn

Bible Truth

Blessed are those who do what is right in God's eyes.

Memory verse

“Blessed are the pure in heart, for they will see God.”

Matthew 5:8

Discover

Fill in the Blanks

1. Jesus taught at the m_____n side.
2. There were many p_____e who wanted to see Jesus.
3. Jesus wanted to teach the crowds what G___ expects from us.

Find it

Find the 8 characteristics that Jesus mentioned in the Sermon on the Mount.

<input type="checkbox"/> Poor	<input type="checkbox"/> Persecuted for His sake
<input type="checkbox"/> Mourn	<input type="checkbox"/> Mocked for His sake
<input type="checkbox"/> Humble	<input type="checkbox"/> Like to steal
<input type="checkbox"/> Hunger for righteousness	<input type="checkbox"/> Love to fight
<input type="checkbox"/> Easy to get Angry	<input type="checkbox"/> Like to tell lies
<input type="checkbox"/> Merciful	<input type="checkbox"/> Love to be praised
<input type="checkbox"/> Pure in heart	<input type="checkbox"/> Love to boast

True/False Circle the correct answer.

1. God blesses those who are rich (Yes / No)
2. God blesses those who are merciful (Yes / No)
3. Jesus said be sad when someone lies about you (Yes / No)

Respond

Which Beatitudes do you find hard to follow? Why?

Prayer

Dear God, Thank you for teaching us the right way to live. Help us Lord, to learn how to live for you. In Jesus' name, Amen.

Lesson 12: THE SERMON ON THE MOUNT

Theme: Living a life that pleases God.

Lesson Aim: That the children will act on living in ways they know will please God.

Bible Reference:
Matthew 5:17-48



Learn

Bible Truth

Jesus wanted His disciples to have a clear understanding of how God wants His people to live.

Memory verse

“In the same way, let your light shine before men, that they may see your good deeds and praise your Father in heaven.”

Matthew 5:16

Discover

Fill in the Blanks

1. Jesus wanted to give a better u_____g of the law.
2. People found it difficult to accept Jesus' te_____.
3. Jesus taught with au_____.

Fix it

The bible verse below is scrambled all over the place. Arrange it back into order by matching the shapes.

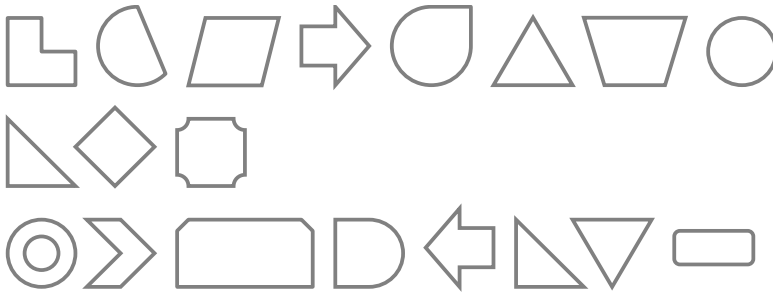

Then you will be able to test and approve what God's will is—his good, pleasing and perfect will.
Romans 12:2

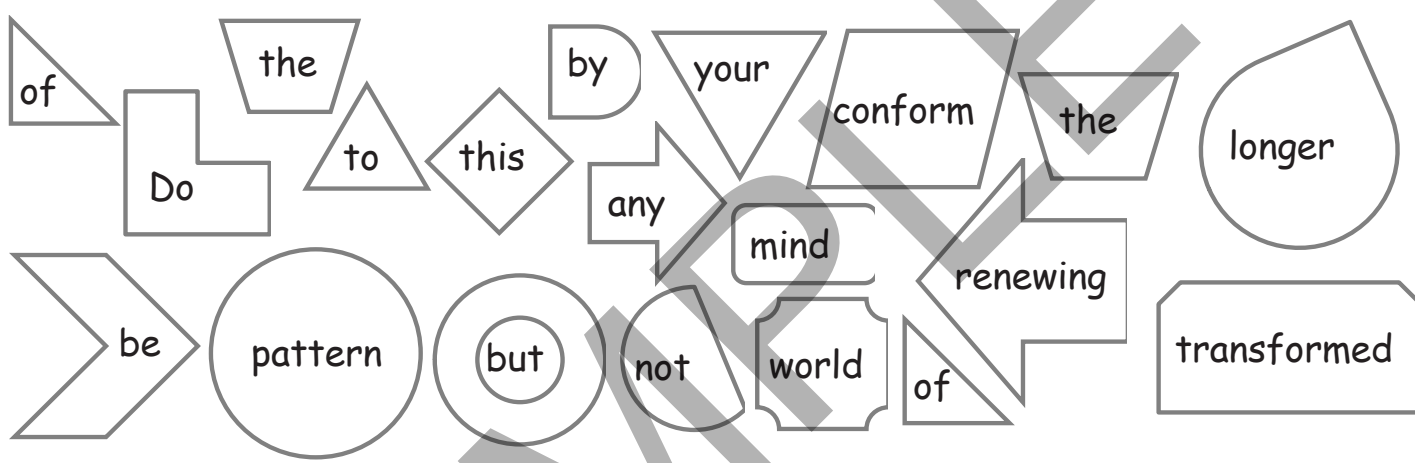

Respond

Imagine you are on an island where you are free to do anything at all. What would happen? List 2 good things:

List 2 bad things:

Prayer

Dear God, help me to live a life that will make you happy. In Jesus' name, Amen.

The Gospel Story Vol. 1

Lesson 13: FAITH, POWER AND AUTHORITY

Theme: Trust in Jesus

Lesson Aim: That the children will entrust their fears of sickness or evil spirits to Jesus because He has authority over all things.

Bible Reference:
Matthew 8:5-13;
Mark 4:35-41; 5:1-20



Learn

Bible Truth

1. Jesus praises the faith of the Roman centurion and heals his servant.
2. Jesus shows His authority over the forces of nature by calming a storm.
3. Jesus shows His authority and power to chase out evil spirits.

Memory verse

They were terrified and asked each other, "Who is this? Even the wind and the waves obey him!"

Mark 4:41

Discover Fill in the Blanks

Jesus performed 3 miracles, they were:-

- a) _____
- b) _____
- c) _____

Draw a comic story.

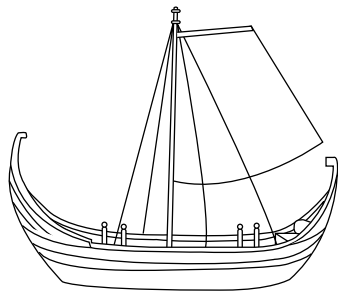

Jesus and his disciples sailed in a boat

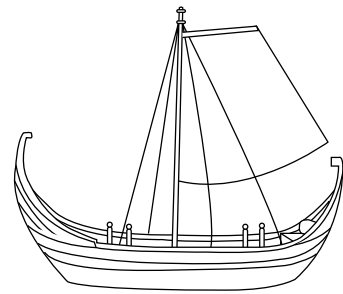

Jesus took a nap while the boat was sailing

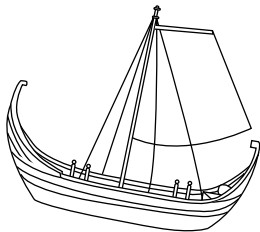

A strong wind started to blow

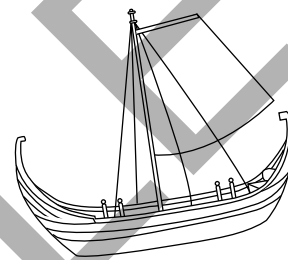

The waves started to spill over the boat

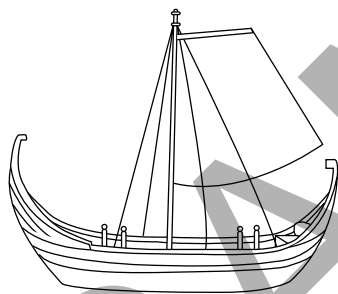

Jesus ordered the wind and the waves to be still

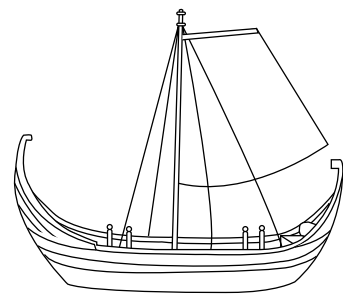

The sea was calm again

Respond

Why is it important to have faith?

Prayer

Dear God, there is nothing in this world you can not do. Because of this we trust and have faith in You. In Jesus' name, Amen

The Gospel Story Vol. 1

Lesson 14: JESUS AND JAIRUS' DAUGHTER

Theme: Jesus heals.
We are to have faith.

Lesson Aim: That the children will learn to place their trust in God even when others around them do not believe.

Bible Reference:
Mark 5:21-43



Learn

Bible Truth

Jesus heals a woman with bleeding problems and raises a dead girl back to life. The two stories show how important it is for us to have faith in our dealings with God.

Memory verse

Ignoring what they said, Jesus told the synagogue ruler, "Don't be afraid; just believe."

Mark 5:36

Discover

Fill in the Blanks

1. J_____ pleaded with Jesus to come and heal his daughter who was ill.
2. The woman who had suffered from bleeding was considered un_____.

Decode it

Find out what Jesus said to Jairus' daughter.

— — — — —
20 1 12 9 20 8 1

— — — — —
11 15 21 13

A= 1	E= 5	I= 9	M= 13	Q= 17	U= 21	Y= 25
B= 2	F= 6	J= 10	N= 14	R= 18	V= 22	Z= 26
C= 3	G= 7	K= 11	O= 15	S= 19	W= 23	
D= 4	H= 8	L= 12	P= 16	T= 20	X= 24	

True / False Circle the correct answer

1. The phrase “Talitha koum” means little girl, I say to you get up! (Yes / No)
2. Jairus did not believe that Jesus could heal his daughter. (Yes / No)
3. The woman was healed by just touching Jesus' clothes. (Yes / No)

Respond

Do you think all these miracles could have happened without faith?

Prayer

Dear God, nothing is impossible for you. We believe that you are a God that can do all the impossible things. In Jesus' name, Amen.

Lesson 15: FEEDING THE GREAT CROWD!

Theme: God will take care of us.

Lesson Aim: That the children will praise God for caring for their physical needs.

Bible Reference:
Matthew 14:13-21;
John 6:1-33



Learn

Bible Truth

Jesus provided spiritual and physical food for the large crowd. Jesus again showed His power over nature in front of His disciples.

Memory verse

“The Lord is my shepherd,
I shall not be in want.”

Psalm 23:1

Discover

Fill in the Blanks

1. Jesus felt p_____ for the large crowd.
2. Jesus fed the crowd with 5 _____ and 2 _____.
3. Jesus walked on w_____.

Find it

What Jesus fed the crowd.

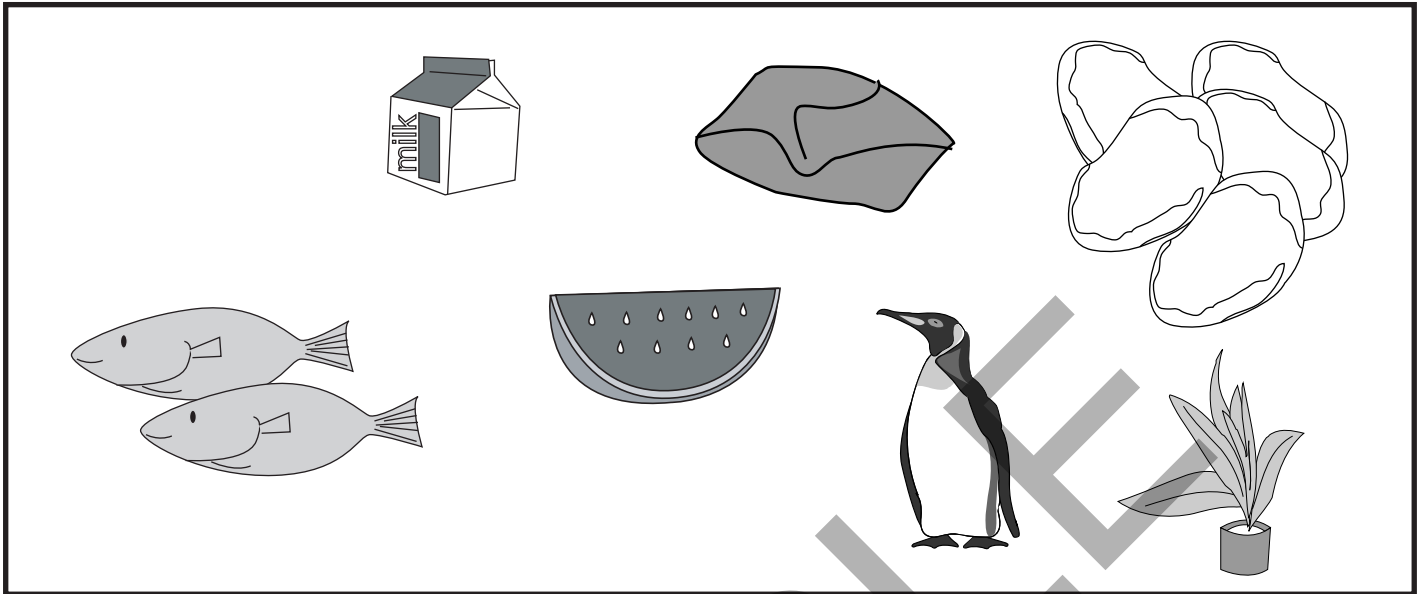

True or False? Circle the correct answer

1. Jesus sent the crowd away so they could buy food for themselves. (Yes/No)
2. There was more than enough food for the crowd. (Yes/No)
3. Peter was able to walk on water. (Yes/No)

Respond

How can we be helpful like the young boy in the story?

Prayer

Dear God, Thank you for taking care of me. I want to be helpful like the young boy in the story. In Jesus' name, Amen.

The Gospel Story Vol. 1

Lesson 16: PETER PROCLAIMS JESUS THE MESSIAH

Theme: Jesus asks the disciples who they think He is.

Lesson Aim: That the children will commit their lives to Jesus in response to His dying as a sacrifice for their sins.

Bible Reference:
Matthew 16:13-26



Learn

Bible Truth

Bible Truth Jesus is the Messiah sent by God to suffer and die as a sacrifice for the sins of the world.

Memory verse

Simon Peter answered, “You are the Christ, the Son of the living God.”

Matthew 16:16

Discover

Read Matthew 16:13-26. Then circle the correct answer.

1. In this story, Jesus brought His disciples into Jerusalem. True / False
2. Some thought Jesus was John the Baptist. True / False
3. Peter said to Jesus, “You are the Messiah, the Son of the Living God.” True / False

Colour the picture.



Respond

How can we thank God for sending Jesus to die for our sins?

Prayer

Dear God, Thank you for sending Jesus the Messiah to die for my sins.

The Gospel Story Vol. 1

Lesson 17: THE TRANSFIGURATION

Theme: Jesus reveals His glory to His 3 closest disciples.

Lesson Aim: That the children will discover that as they are faithful to God, He will show them the things that are close to His heart.

Bible Reference:
Matthew 17:1-13

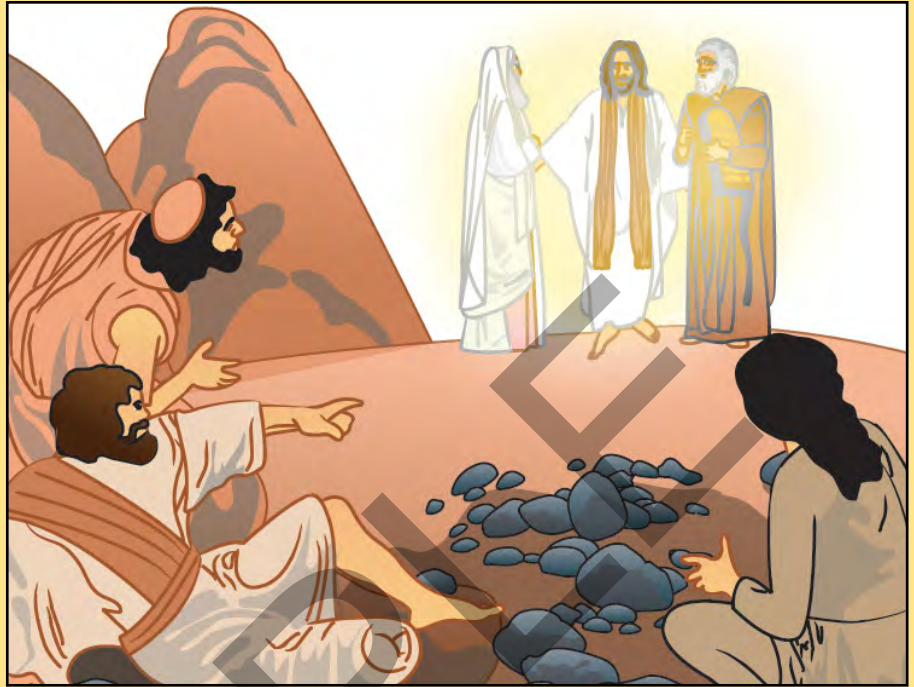

Learn

Bible Truth

As we walk faithfully with God, He will reveal to us the things that are close to His heart.

Memory verse

The Lord confides in those who fear him; he makes his covenant known to them.

Psalm 25:14.

Discover

Circle the disciples who witnessed the Transfiguration of Jesus.

Andrew

Thaddeus

Jonah

Philip

John

Nathaniel

Judas

Peter

Matthew

James

Draw a comic picture on the Transfiguration.

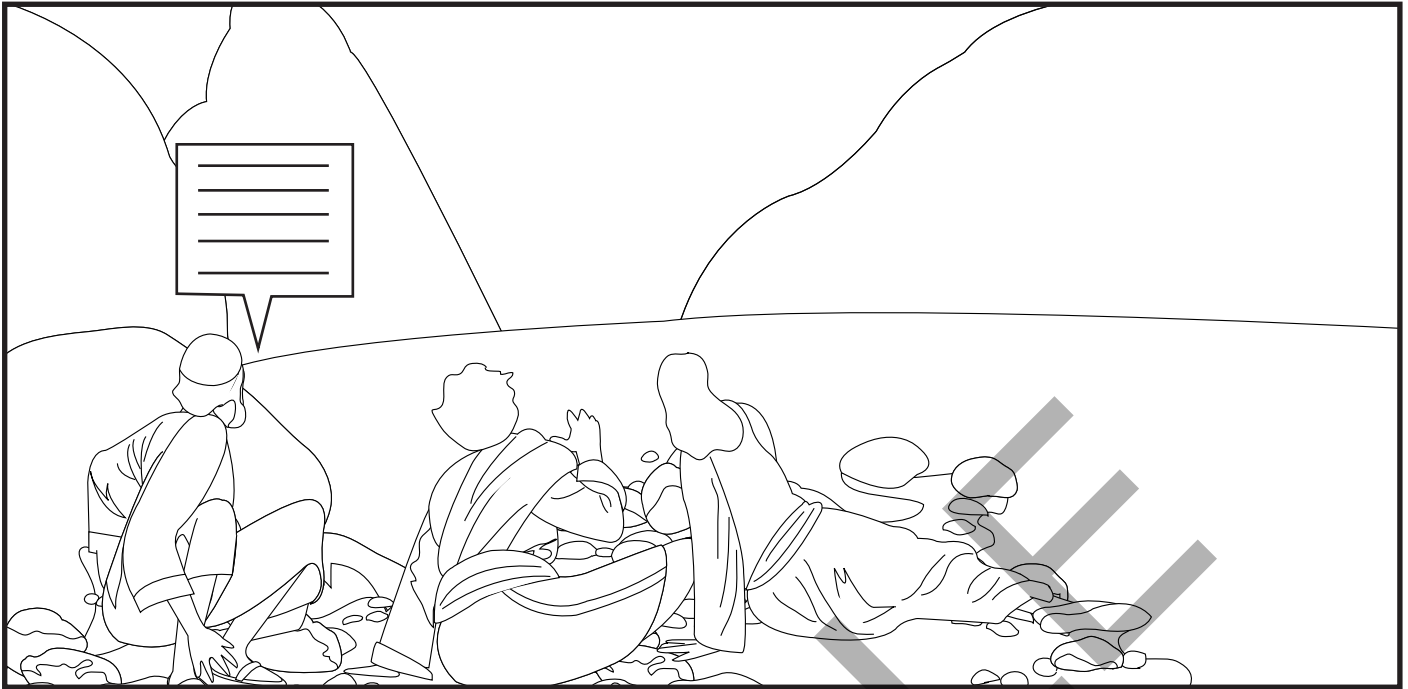

Then suddenly, _____

Peter said, “ _____ ”

But Jesus said, “ _____ ”

Respond

Isn't God so good that He shares His heart and His plans with those who love Him and are close to Him? One of the ways to grow close to Jesus is to desire to know Him better and be faithful to obey Him.

List down what you can do to get to know Jesus more:

1. _____
2. _____

List down how you can grow to be more obedient to Jesus:

1. _____
2. _____

Prayer

Tell Jesus how much you love Him and desire to grow closer to Him.

The Gospel Story Vol. 2

Lesson 18: THE SAMARITAN WOMAN AND THE SAMARITAN

Bible Truth: Jesus teaches us to love and help others in need regardless of their race, gender and differences in outlook.

Objective: Make efforts to care for others who are in need regardless of how different these people might be from you.

Bible Reference:
Matthew 22:39

Memory verse: “Love your neighbour as yourself.”
Matthew 22:39



Lessons from Story:

1. Jesus breaks the traditional barriers between Jews and Samaritans and between genders.
2. Jesus purposely portrayed the Samaritan as the hero who helps his neighbour.

Discover

1. The Jews didn't get along with the _____.
2. The _____ and _____ didn't help the man who was robbed.

Find the good Samaritan

Colour the pictures that have helping children.

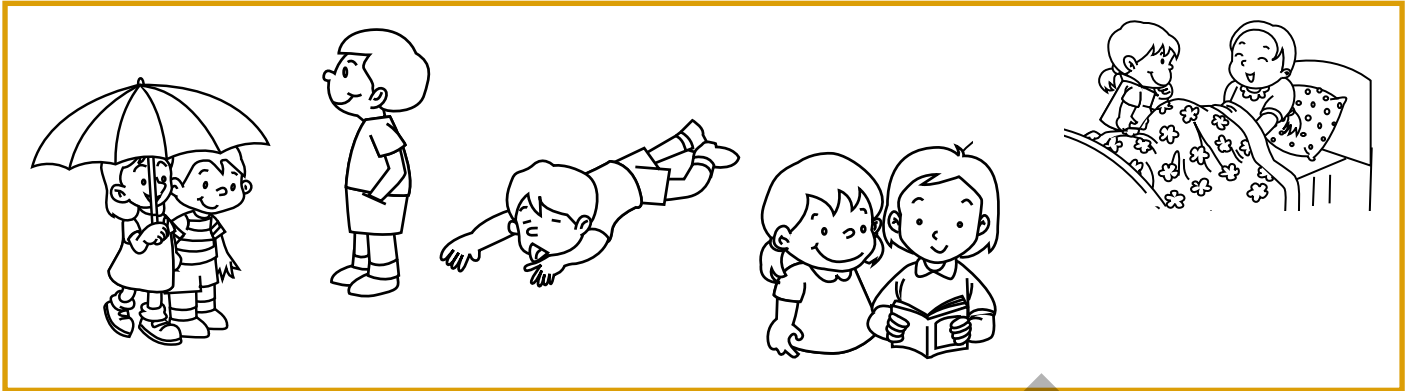

Circle the correct answer

1. Jesus said to “Love the Lord your God with all you heart, with all your mind.” (True / False)
2. Your neighbour is only someone who lives next to you. (Yes / False)

Respond

1. Who is your neighbour?

2. It is easy to love someone we like. What about people we don't like or people who are different from us? Is there someone like that in your school? If yes, how do we take today's lesson and apply it into our life?

Prayer

Dear God, thank you for showing me to love others who are not like me. Help me to be nice and friendly to them. In Jesus' name, Amen

The Gospel Story Vol. 2

Lesson 19: THE IMPORTANCE OF BEING HUMBLE

Bible Truth: Jesus calls us to be humble because it is the humble who touches God's heart.

Objective: That the children will ask God to help them to be humble.

Bible Reference:

Luke 18:9-14;
Matthew 18:1-6

Memory verse: "For everyone who exalts himself will be humbled, and he who humbles himself will be exalted."

Luke 18:14



Lessons from Story:

1. Luke 18:14 "... all who make themselves great will be humbled, and all who humble themselves will be made great."
2. Jesus uses a little child to show His disciples that the Kingdom of Heaven honours those who humble themselves and become innocent and trusting like little children.

Discover Fill in the blanks with answers from below.

1. Jesus was teaching people who were _____.
2. The Pharisee was _____.
3. The disciples were arguing about who would be the _____ in the Kingdom of heaven.

a. proud

b. greatest

c. proud

The Puffed-up Man

A proud person is like a puffed-up balloon. He/She thinks of himself/herself as high and mighty and looks down on others.

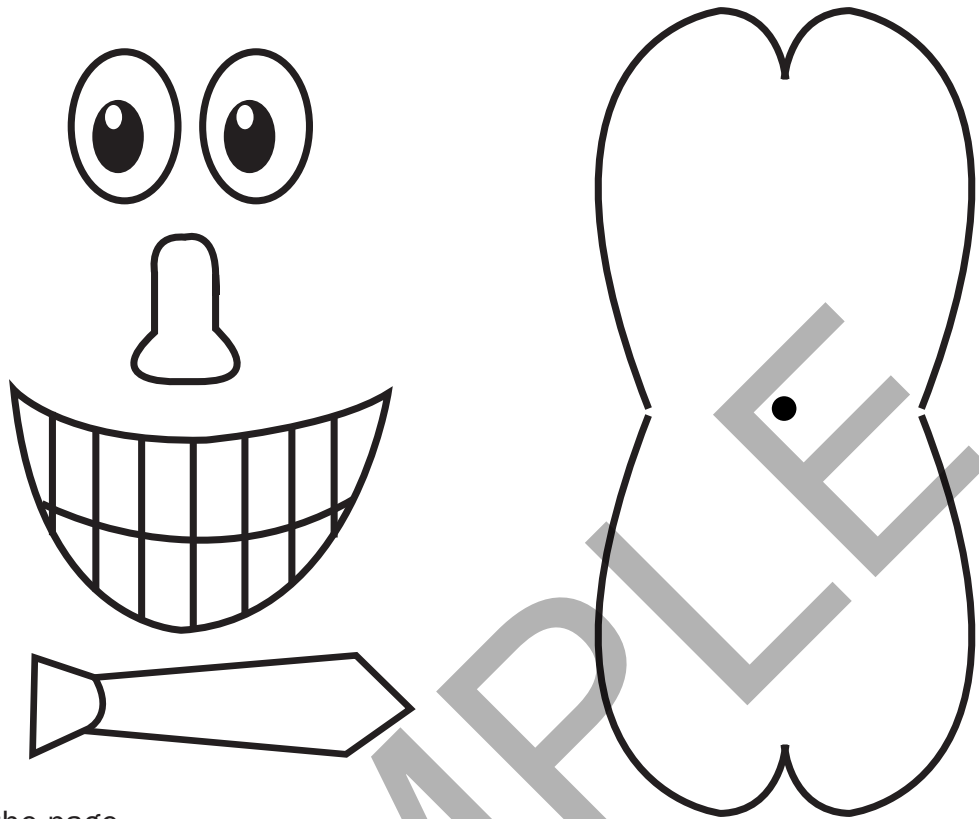

Photostat the page.

Punch a hole in the center of each feet pattern. Assist the children who need help blowing up their balloons. Demonstrate to the children how to attach the feet to the balloon by pulling the tied end through the hole in the feet. They should glue on the other pieces. Discuss how we sometimes say things that are ugly about a friend to puff up ourselves. (E.g: "My hair looks better than yours," "you sure bombed that test.")

Respond

1. Why is being humble important?

2. How do we become more humble?

Prayer

Dear God, help me be humble and not think too highly of myself. In Jesus' name, Amen.

The Gospel Story Vol. 2

Lesson 20: THE PARABLE OF THE LOST AND FOUND

Bible Truth: God is our Father

Objective: To know that God loves us no matter how good or bad we are.

Bible Reference:

Luke 15:1-31

Memory verse: “In the same way, I tell you, there is rejoicing in the presence of the angels of God over one sinner who repents.” Luke 15:10



Lessons from Story:

1. God rejoices over one person who repents regardless of how sinful he is rather than over those who think they are already righteous and do not need to repent.
2. We are like the lost son who needs to repent. God is like the loving father who reaches out to his lost son.
3. The story also warns us not to become like the proud older brother.

Discover True or False

1. The good shepherd didn't care about his lost sheep. True / False
2. The prodigal son spent all his money on foolish things . True / False
3. The father was very happy when his son came home. True / False
4. The pharisees were very happy with the story. True / False

Find the way

Help the prodigal son find his way back home

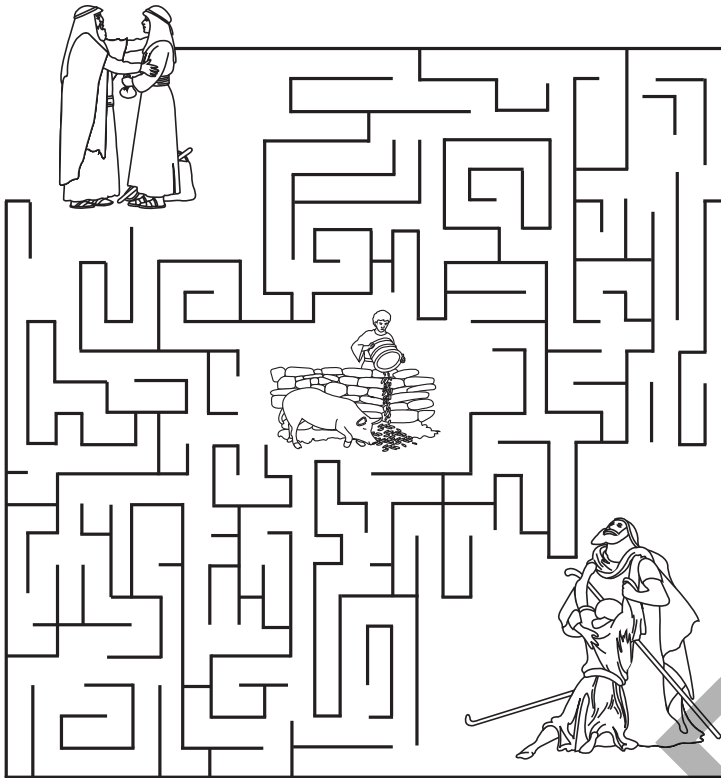

Quiz

Choose the correct answer

long **property** **party**
pigs

1. The prodigal son wanted his share of _____.
2. The prodigal son could only find a job feeding _____.
3. The father saw the son while he was a _____ way from home.
4. The father threw a _____ for the son.

Respond

1. Why wasn't the father angry at the prodigal son?

2. God is like the father. If we repent and confess our sin He will forgive us and welcome us back. Is there something you've done wrong, write it down and talk to God and ask for forgiveness.

Prayer

Dear God, thank you that you love me so much, I'm sorry for _____.
In Jesus' Name, Amen.

The Gospel Story Vol. 2

Lesson 21: JESUS AND LAZARAUS

Bible Truth: Jesus our Saviour

Objective: To trust that God will raise us to life again when Jesus comes back and we will live with Him forever.

Bible Reference:

John 11:1-57

Memory verse: Jesus said to her, "I am the resurrection and the life. He who believes in me will live, even though he dies."

John 11:25.

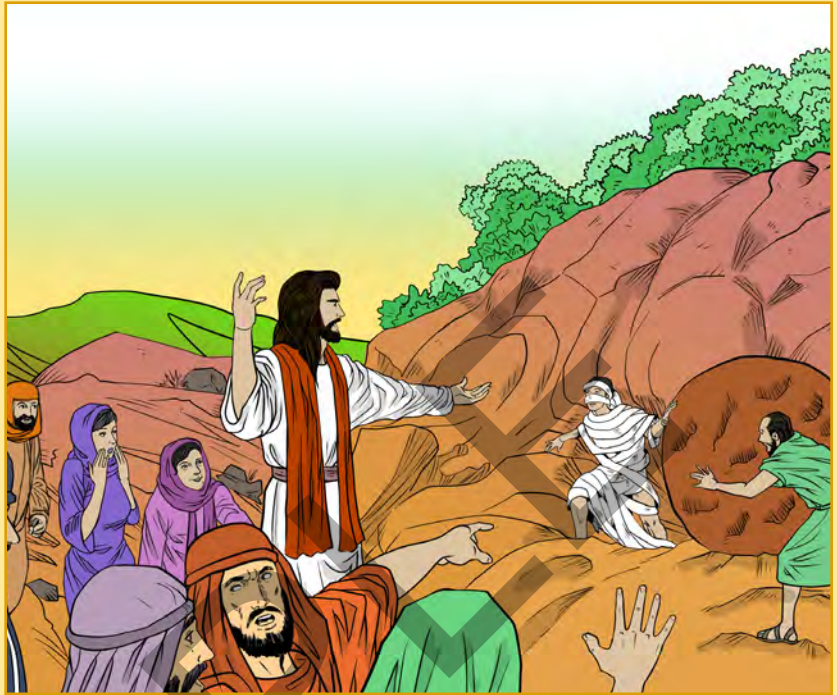

Lessons from Story:

1. Jesus raised Lazarus from the dead in front of the disciples and the people to prove that He is the Son of God. He explained to Martha and showed the people that they need not fear physical death, but to believe and know that He has the power to give them life beyond death.
2. The story also illustrates the humanity of Jesus. Although He knew that He would soon raise Lazarus from the dead, Jesus wept when He saw the grief and sadness of His friends.

Discover Fill in the blanks

1. Lazarus was (ill / well).
2. Jesus knew that Lazarus was (dead / alive).
3. Jesus was moved by the (sorrow / faith) of Mary and Martha.
4. Jesus called Lazarus to (wake up / come out).

Decode it

What did Jesus say to Martha?

☉	♌	♍	♎	♏	♐	♑	♒	♓	♈	er	&	●	○
A	B	C	D	E	F	G	H	I	J	K	L	M	

■	□	◻	◻	◻	◆	◆	◆	◆	◆	⊗	⊗	⌘
N	O	P	Q	R	S	T	U	V	W	X	Y	Z

⊗ ☉○
◆ ♁ ♏
◻ ♏ ◆ ◻ ◻ ♏ ♍ ◆ ⊗ ◻ ■

☉ ■ ♎
◆ ♁ ♏
● ⊗ ♐ ♏

Respond

1. What can we learn from Mary and Martha?

2. Why do you think Jesus raised Lazarus in front of the disciples and the people?

3. Do you believe that you will live forever with Jesus?

Prayer

Dear God, thank you for the story of Lazarus. I believe that Jesus has the power to raise people from the dead and that I will live forever with Him. In Jesus' Name, Amen.

The Gospel Story Vol. 2

Lesson 22: JESUS AND LAZARAUS

Bible Truth: Willing to show that we're sorry.

Objective: That the children will show through their actions when they are sorry for the wrong things they have done.

Bible Reference:
Luke 18:35-43; 19:1-10

Memory verse: "The good man brings good things out of the good stored up in him, and the evil man brings evil out of the evil stored up in him."
Matthew 12:35



Lessons from Story:

1. The blind man had faith and boldness in asking for God's mercy. The result was a miracle with all the witnesses praising God.
2. A chief tax collector shows his repentance and receives forgiveness from Jesus.
3. It is not the proud self-righteous people like the Pharisees who are on the right path to heaven. Rather it is those who are repentant and seek God's forgiveness who will receive salvation.

Discover Fill in the blanks from the answers below

1. Zacchaeus was :-
a) _____ b) _____
2. The tree Zacchaeus climbed was a _____
3. Zacchaeus gave _____ his belongings to the poor and if he _____ anyone, he would pay back _____ times as much

a. sychamore tree	b. chief tax collector	c. half
d. short man	e. cheated	f. four

Sequencing the story

Colour and cut the pictures below to make your own story book.

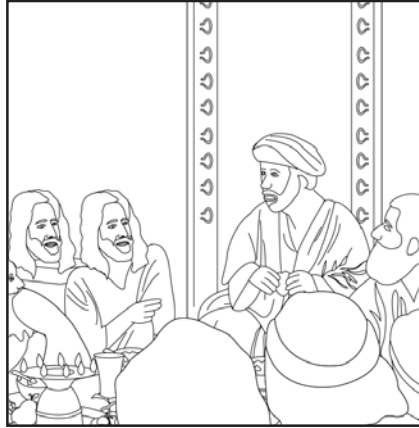

Respond

1. When Zacchaeus felt sorry for the bad things he had done and showed that he was sorry by giving away his possessions, how do you show that you're sorry?

Prayer

Dear God, help me to show others in my actions when I am sorry. In Jesus' Name, Amen.

The Gospel Story Vol. 2

Lesson 23: JESUS ENTERS JERUSALEM

Bible Truth: Jesus is the King of Kings.

Objective: That the children will allow Jesus to reign as king in their lives.

Bible Reference:
Matthew 21:1-11;
Mark 11:15-19

Memory verse: “On his robe and on his thigh he has this name written: King of Kings and Lord of Lords.” Revelation 19:16.

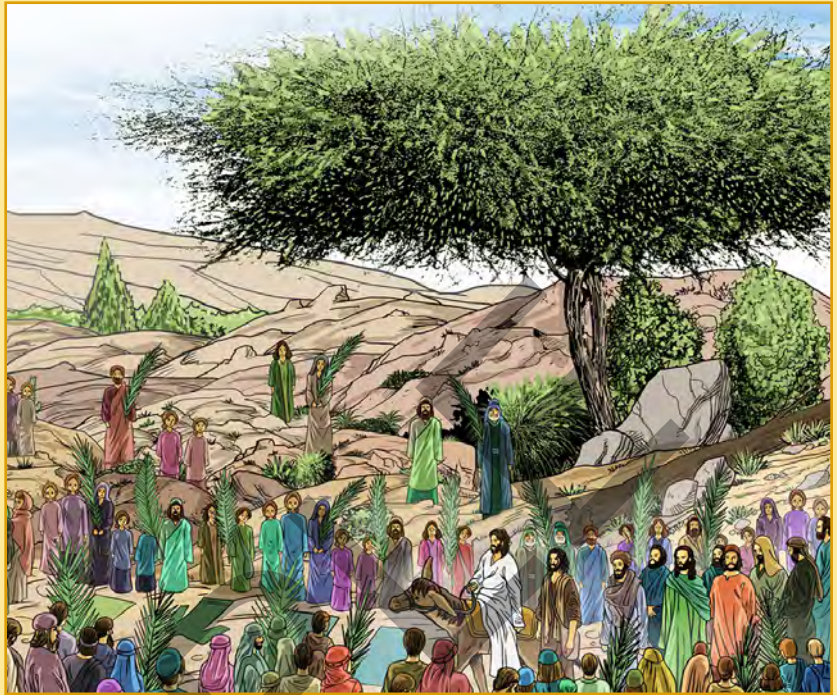

Lessons from Story:

1. As Jesus enters Jerusalem, there is a large crowd waiting to hail him as king. But setting up a new earthly government was not what Jesus had in mind. His mission was not to bring Israel out of bondage of the Romans, but out from slavery to evil and sin.
2. Jesus clears the temple of the wicked traders in the Temple courtyard.

Discover Fill in the blanks from the answers below

1. Jesus entered Jerusalem during the _____ season.
2. Jesus used a _____ to enter Jerusalem.
3. People spread _____, some others cut _____ on the road.

a. branches

b. Passover

c. donkey

d. cloaks

Let Jesus be on the throne

Using artcard, cut according to the shapes of A, B, C, D, and E.
The sizes and measurements are up to your preference.

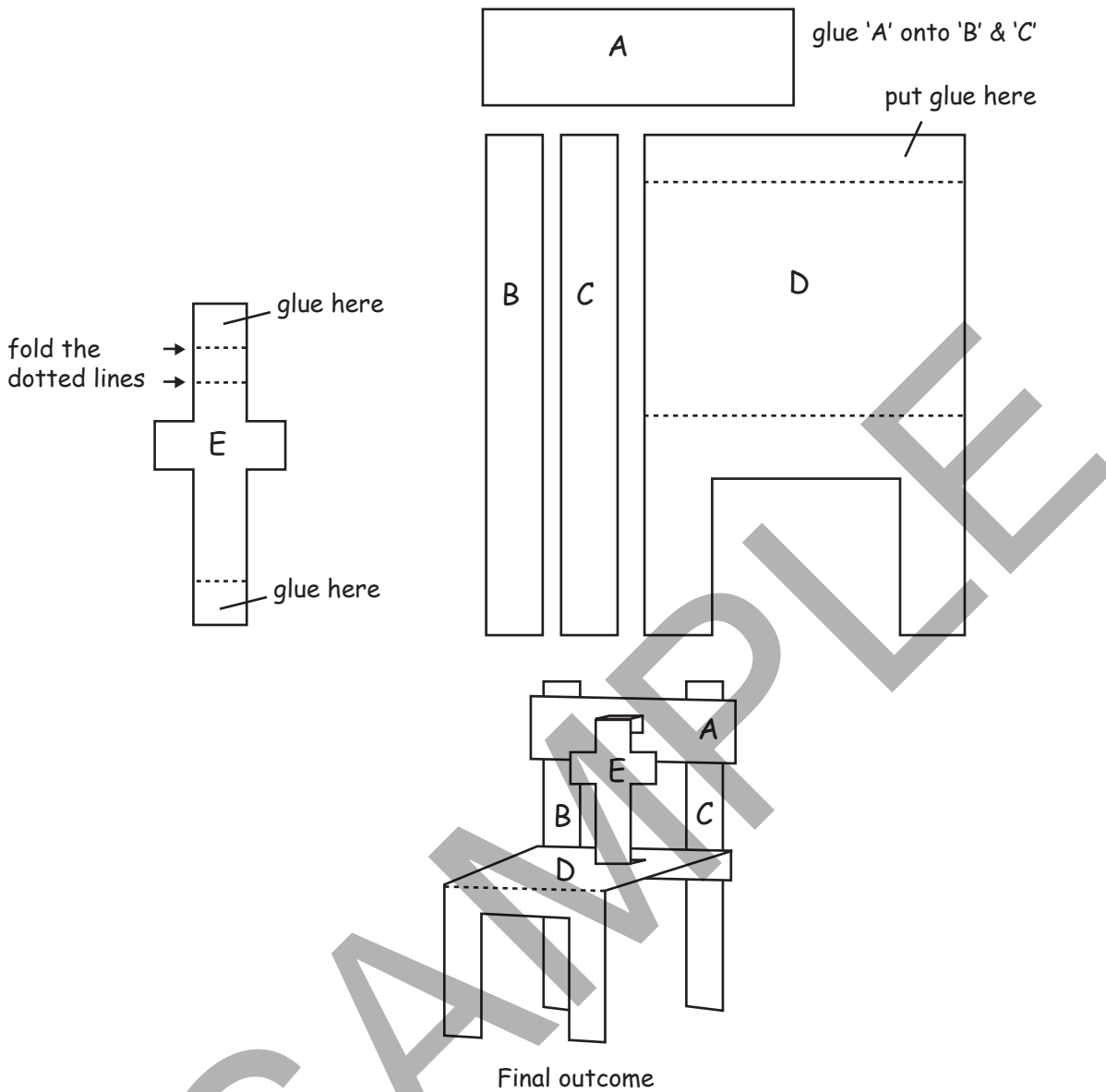

Respond

Jesus is King of our lives. How do we allow Him to reign our lives?

Prayer

Dear God, You are the King of Kings, You deserve all praise. In Jesus' name, Amen.

The Gospel Story Vol. 2

Lesson 24: JESUS AND NICODEMUS

Bible Truth: God loves us.

Objective: That the children will thank God for loving them so much that He sent Jesus into the world to save them from their sins.

Bible Reference:

John 3:1-21

Memory verse: For God so loved the world that he gave his one and only Son, that whoever believes in him shall not perish but have eternal life.” John 3:16.



Lessons from Story:

In His encounter with Nicodemus, Jesus explains the true reason for His coming to the world. This is recorded for us in John 3:16 which says, “For God so loved the world that He gave His one and only Son, that whoever believes in Him shall not perish but have eternal life.”

Discover True or False

1. Nicodemus was a Pharisee. True / False
2. Nicodemus could not understand what Jesus said at first. True / False
3. Jesus said that people only need to be born physically. True / False

Decode it

What did Jesus say to Nicodemus?

A	B	C	D	E	F	G	H	I	J	K	L	M	N	O	P	Q	R	S	T	U	V	W	X	Y	Z
5	20	26	11	18	21	3	12	10	16	8	2	22	1	7	15	24	6	4	14	9	13	17	19	25	23

21 7 6 3 7 11 4 7 2 7 13 18 11 14 12 18 17 7 6 2 11

14 12 5 14 12 18 3 5 13 18 10 4 7 1 2 25 4 7 1 14 12 5 14

18 13 18 6 25 7 1 18 17 12 7 20 18 2 10 18 13 18 4 10 1 12 10 22

22 5 25 1 7 14 11 10 18 20 9 14 12 5 13 18 18 14 18 6 1 5 2

2 10 21 18

Respond

1. Why did Nicodemus come to see Jesus?

2. What can you learn from this story?

Prayer

Dear God, thank you for loving us and sending Jesus to save us. In Jesus' Name, Amen.

The Gospel Story Vol. 2

Lesson 25: THE LORD'S SUPPER

Bible Truth: A Servant- Heart

Objective: That the children will follow Jesus' example of serving others with a servant's heart.

Bible Reference:
Matthew 26:14-30;
John 13:1-34

Memory verse: "A new command I give you: Love one another. As I have loved you, so you must love one another." John 13:34

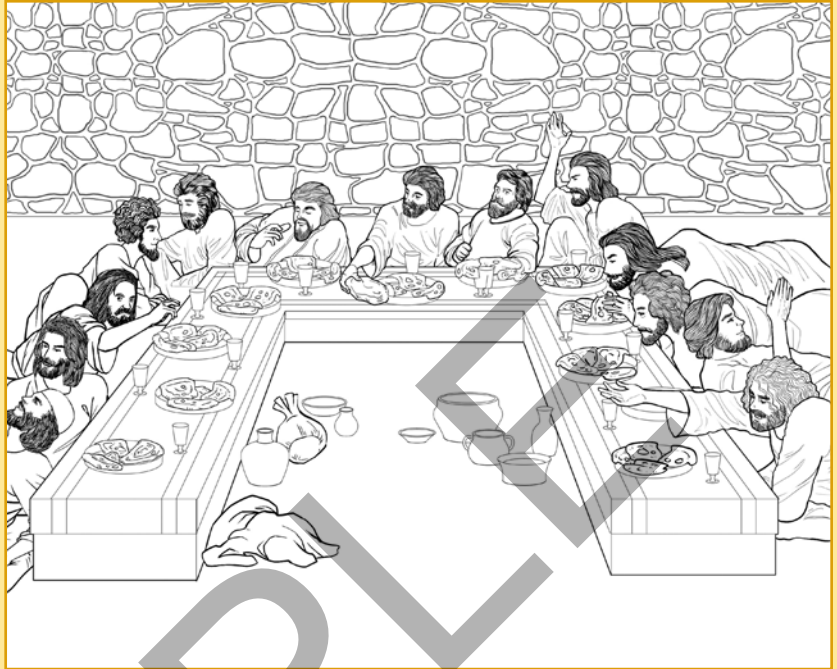

Lessons from Story:

1. Judas plots with the chief priests to betray Jesus.
2. Jesus washes the feet of His disciples. By doing so He gives us an example of the humble and servant spirit that must be adopted by all His followers.

Discover Circle the correct answer.

1. (Simon Peter / Judas) was planning to betray Jesus.
2. The Pharisees paid Jesus's disciple (50 pieces of gold / 30 pieces of silver).
3. Jesus washed His disciple's (hands / feet).
4. Peter asked Jesus to not only wash his feet, but his (whole body / hands) as well.

Search for it

Look for the answers below.

U	B	W	B	C	P	D	T
Q	P	N	T	D	D	X	B
T	G	P	N	A	F	G	D
I	T	E	E	F	J	N	W
K	P	R	M	R	I	U	M
H	B	A	R	S	I	E	B
R	E	T	A	W	F	O	J
E	B	B	G	V	R	H	X

BASIN

UPPER

GARMENT

FEET

BREAD

WATER

1. The Lord's Supper happened during the Feast of the Unleavened _____.
2. Disciples were to prepare an _____ room.
3. Jesus took off his outer _____ and poured _____ into a _____ and began washing His disciple's _____.

Respond

1. What was so special about Jesus washing His disciple's feet? What can we learn from this story?

2. Jesus was serving His disciples by washing their feet, How do we follow Jesus's example of serving others?

Prayer

Dear God, Thank you for Jesus who showed us how to serve others with a servant-heart. Help us to follow in His example. In Jesus' Name, Amen.

The Gospel Story Vol. 2

Lesson 26: THE PASSOVER MEAL AND ITS MEANING

Bible Truth: God makes a new covenant with us through the shedding of Jesus' blood to atone for our sins.

Objective: That the children will understand why the shedding of Jesus' blood is able to take away their sins.

Bible Reference: Mark 14:22-26; John 13:18-38

Memory verse: "This is my blood of the covenant, which is poured out for many for the forgiveness of sins." Matthew 26:28



Lessons from Story:

1. Jesus tells them He is going to be betrayed.
2. Jesus uses the Passover meal to illustrate what He is about to do. Jesus announces a New Covenant, where His death will be the final sacrifice made to pay and deliver all believers from sin.

Discover Fill in the Blanks

1. Jesus took the _____ and broke it.
2. The bread represents Jesus's _____.
3. After supper Jesus took the _____.
4. The wine in the cup represents Jesus _____.

Sequencing the story

Number the pictures in their proper order and write out the story.

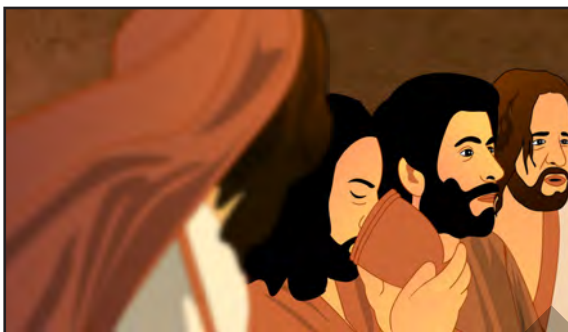

Respond

1. Why is the Bread and Wine so significant in the church?

2. Why is it important to remember the Bread and the Wine?

Prayer

Dear God, thank you Jesus for Bread and Wine. Help us to remember of what you did on the cross. In Jesus' Name, Amen.

The Gospel Story Vol. 2

Lesson 27: THE GARDEN OF GETHSEMANE

Bible Truth: Following God.

Objective: That the children will choose to follow God even when there is difficulty.

Bible Reference: Mark 14:27-42, 47-56

Memory verse: “Abba, Father,” he said, “everything is possible for you. Take this cup from me. Yet not what I will, but what You will.” Mark 14:36



Lessons from Story:

1. Jesus tells Peter that he will soon deny his Master. He said this so that later, Peter will be able to look back and repent.
2. Jesus knows the suffering He will soon undergo at the cross, but He submits to the will of His Father in heaven.

Discover Fill in the Blanks

1. Jesus predicted that Peter will say he does not know who Jesus is _____ times.
2. The Disciples were _____ while Jesus was praying.
3. Judas betrayed Jesus with a _____.
4. Jesus _____ a man struck by Peter.

The way to Gethsemane

Colour the picture and find the way.

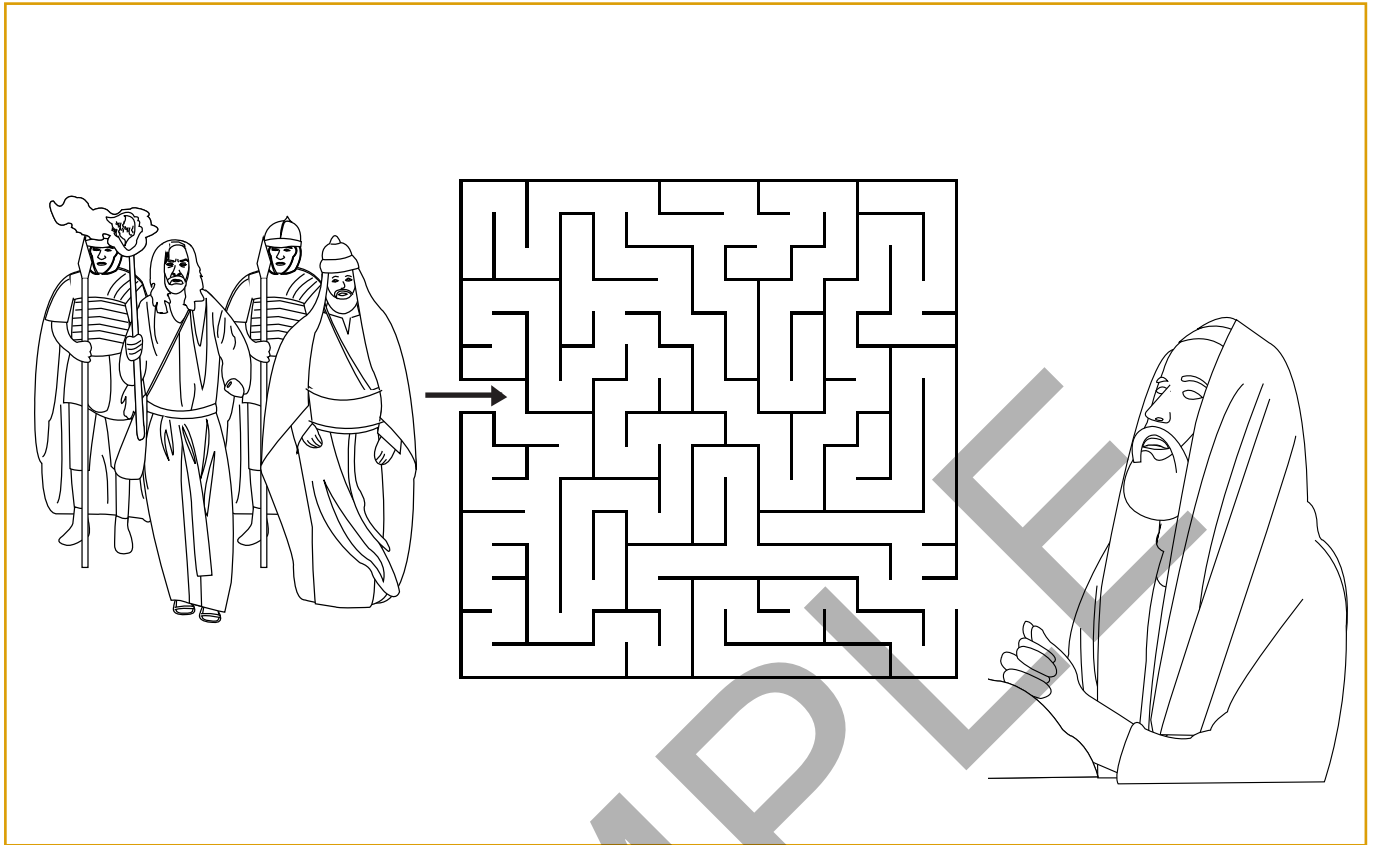

Respond

1. Why was Jesus feeling so troubled while He was praying?

2. Even though Jesus found it hard to follow God's way, He still obeyed God. In your life there are times when you find it hard to obey God. List them down and talk to God about them.

Prayer

Dear God, _____.

In Jesus' Name, Amen.

The Gospel Story Vol. 2

Lesson 28: JESUS IS TRIED BY THE JEWS

Bible Truth: Being like Jesus.

Objective: That the children will learn not to respond the same when they are treated badly by others.

Bible Reference: Mark 14:53-72

Memory verse: “Do not repay evil with evil or insult with insult, but with blessing...”
1 Peter 3:9a

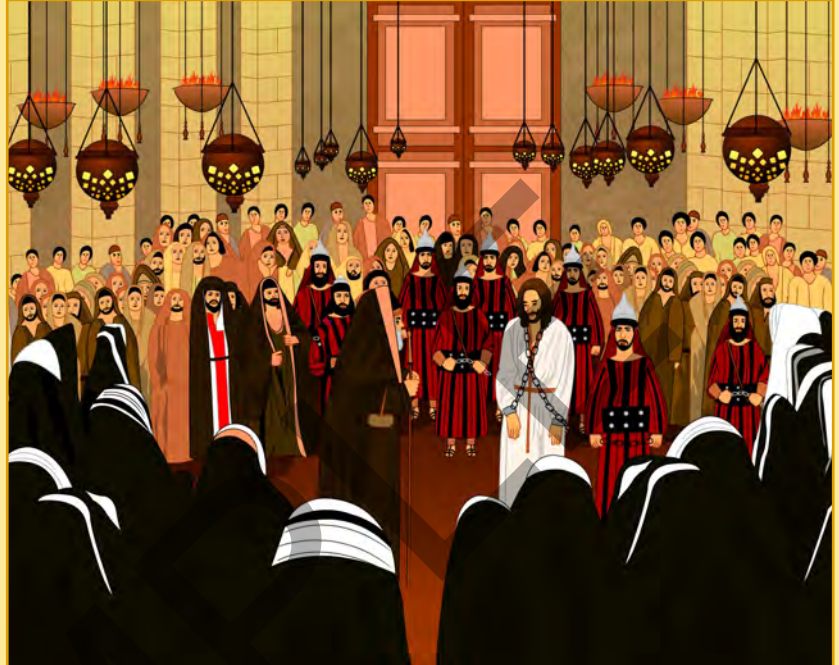

Lessons from Story:

1. The trial of Jesus was not carried out with justice. The Jewish leaders put forward false witnesses who contradicted each other. In the end, they convicted Him for blasphemy.
2. But because they could not impose a death sentence on Jesus, they sent Him to the Roman Governor Pilate.

Discover True or False

1. The chief priest and the whole council find evidence against Jesus. True / False
2. Witnesses were lying about Jesus. True / False
3. Jesus claims to be the Son of God. True / False
4. Everyone voted against the decision of the High Priest. True / False

Wisdom Reminders

When Jesus was treated badly He didn't treat them back the same way. He forgave these people and died for them at the cross. Make a reminder of these important words. Colour the words in blue. Decorate the remaining spaces with colour paper.

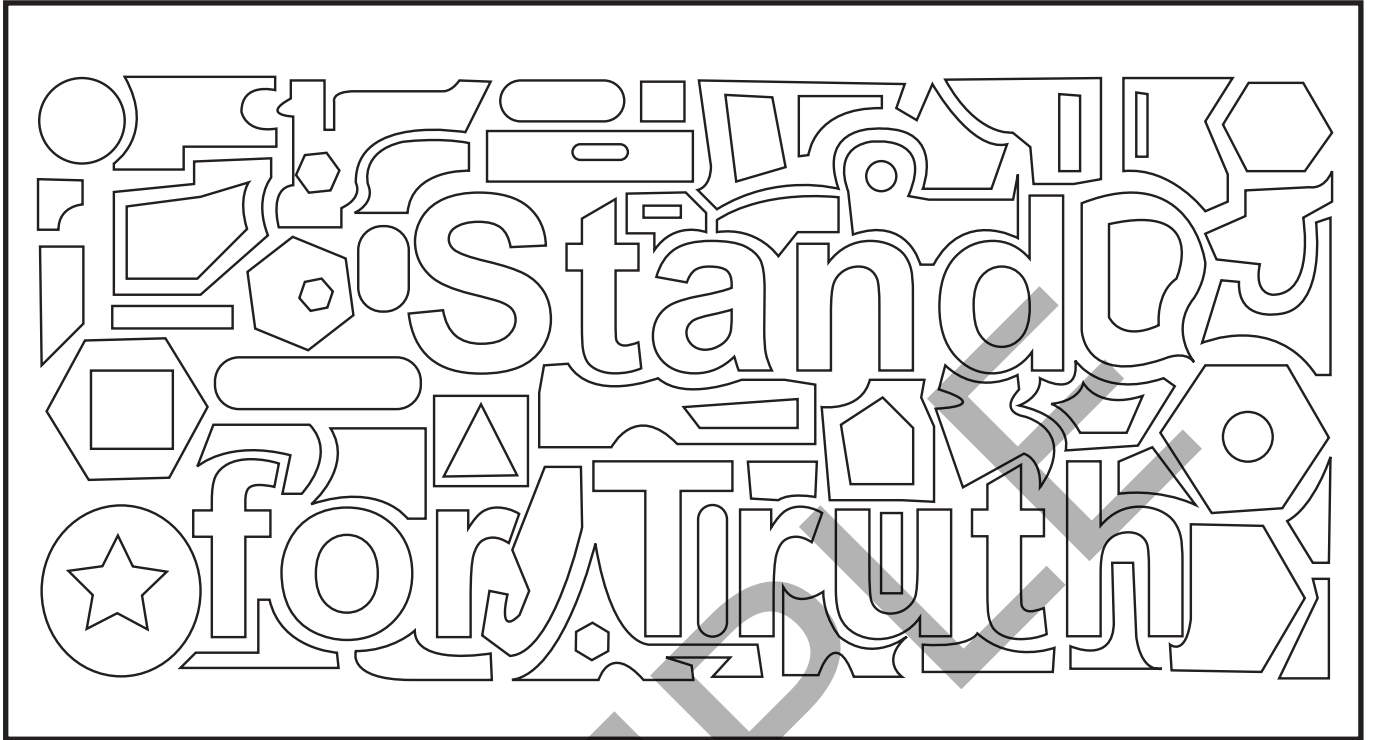

Respond

1. What was Jesus accused of?

2. What can we learn from Jesus in this story?

Prayer

Dear God, help me to be like Jesus and not treat others badly when they treat me badly.
In Jesus' Name, Amen.

The Gospel Story Vol. 2

Lesson 29: JESUS STANDS BEFORE PILATE

Bible Truth: Stand up for what is right.

Objective: That the children will stand up for what is right even when others think differently from them.

Bible Reference:

John 18:28 - 19:16; Matthew 27:24-26

Memory verse: “But even if you should suffer for what is right, you are blessed.” 1 Peter 3:14



Lessons from Story:

1. Pilate does not care about their religious rules. So in front of Pilate the chief priests quickly change the accusation against Jesus from blasphemy to dangerous political trouble-maker.
2. Pilate correctly judges that Jesus has not committed any crime. But he is afraid of the priests who threaten to cause a riot. He then agrees to sentence Jesus to crucifixion.

Discover Circle the correct answer

1. Jesus was led to (the chief priest / Pilate) to be crucified.
2. Pilate (found / could not find) Jesus guilty.
3. Pilate set (Jesus / Barabbas) free.
4. After Pilate passed the sentence he washed his (hands / feet).

Search for it

A	S	Y	L	U	W	I	G	D	A
R	F	S	S	T	D	O	E	O	V
J	V	R	J	H	S	I	T	D	V
W	N	H	A	A	F	I	Y	Q	L
E	G	O	L	I	X	D	Y	M	S
J	O	P	C	Y	D	F	K	U	H
T	M	U	A	K	C	R	I	D	M
X	R	E	U	G	R	D	N	S	J
C	G	U	I	L	T	Y	G	V	F
Z	M	C	T	N	M	K	F	D	Y

AFRAID

KING

CRUCIFIED

GUILTY

1. Pilate asked Jesus if he was the _____ of the Jews.
2. Pilate could not find Jesus _____.
3. Pilate was _____ that a riot might break out
4. Jesus was sent to be _____.

Respond

1. Pilate sent Jesus to be crucified because he was afraid of the Jews, what can we learn from this?

2. Why should we stand up for what is right?

Prayer

Dear God, help me to stand up for what is right even though my friend may not agree with me. In Jesus' Name, Amen.

The Gospel Story Vol. 2

Lesson 30: THE CRUCIFIXION

Bible Truth: Forgiveness.

Objective: That the children will choose to forgive those who have hurt them.

Bible Reference:

Luke 23:26-43;

John 19:24-27

Memory verse: “Forgive us our sins for we also forgive everyone who sins against us.”

Luke 11:4



Lessons from Story:

1. Jesus is crucified. The priests and crowd mock Him. Two men are crucified next to Him. One mocks him, while the other asks for forgiveness. Jesus assures him of forgiveness.
2. Jesus gives final instructions to His disciple and to His mother.

Discover Fill in the blanks

1. Jesus was crucified at a place called _____.
2. There were _____ criminals who were also crucified with Jesus
3. The soldiers divided up Jesus's _____ by gambling.
4. After Jesus died the curtain in the temple was _____ in two from top to bottom.

Decode it

What did Jesus say when He was being crucified

A	B	C	D	E	F	G	H	I	J	K	L	M	N	O	P	Q	R	S	T	U	V	W	X	Y	Z
17	3	2	16	15	4	25	12	11	22	1	6	10	26	21	5	7	8	19	24	23	18	13	20	14	9

4 21 8 25 11 18 15 24 12 15 10 4 17 24 12 15 8 24 12 15 14

16 21 26 24 1 26 21 13 13 12 17 24 24 12 15 14 17 8 15 16 21 11 26 25

23 : 34

6 23 1 15

Respond

1. Jesus showed us that we need to forgive others even though they may not be sorry for what they did, How can you follow in Jesus' example in our homes or at school?

2. What ways can you show your friends that you forgive them?

Prayer

Dear God, thank you for sending your Son Jesus to die for me. Teach me to forgive others as You are a forgiving God. In Jesus' Name, Amen.

The Gospel Story Vol. 2

Lesson 31: THE HOUR AFTER THE CRUCIFIXION

Bible Truth: Jesus the Saviour.

Objective: That the children will respond in love to Jesus as they realise how much suffering He went through in order to save them from their sins.

Bible Reference:
Matthew 27:45-61;
John 19:30-37

Memory verse: “He himself bore our sins in his body on the tree, so that we might die to sins and live for righteousness; by his wounds you have been healed.”
1 Peter 2:24



Lessons from Story:

1. The events that took place immediately after Jesus died on the cross prove that He was truly the Son of God.
2. A soldier's spear confirms that Jesus had died before they took His body down for burial.

Discover Fill in the blanks

1. After Jesus died the curtain in the temple was _____ in two from top to bottom.
2. An army officer said _____
3. Jesus' body was wrapped in _____ and _____.

Think

Put a tick '✓' in the boxes beside the sentences you think are correct.

When Jesus said, "Eli, Eli, lema sabachthani" which means "My God, my God, why have you forsaken me?", why do you think He said that?

- It was a deep expression of sorrow when Jesus took the sins of the world and was separated from God.
- Jesus questioned God because He was having too much pain.
- Jesus did not understand why He had to go through all that.

Jesus suffered all that

- so that we do not have to experience eternal separation from God.
- to show us God's love.
- because He had no choice.

Many unusual things took place upon Jesus' death...

- the curtain in the temple was torn in two from top to bottom
- the earth shook and the rocks split
- the tombs broke open and the bodies of many holy people who had died were raised to life
- darkness covered all the land

Respond

The soldier who witnessed the crucifixion said Jesus was indeed the Son of God. What can we learn from this story?

Prayer

Dear God, thank you for Jesus' dying on the cross for me.
In Jesus' Name, Amen.

The Gospel Story Vol. 2

Lesson 32: THE RESURRECTION

Bible Truth: Jesus is alive.

Objective: That the children will be encouraged to know that God has the power to fulfill all that He has promised in His Word.

Bible Reference:

Matt 27:62-66; 28:1-10;
John 20:3-29

Memory verse: “God has raised this Jesus to life, and we are all witnesses of the fact.” Acts 2:32

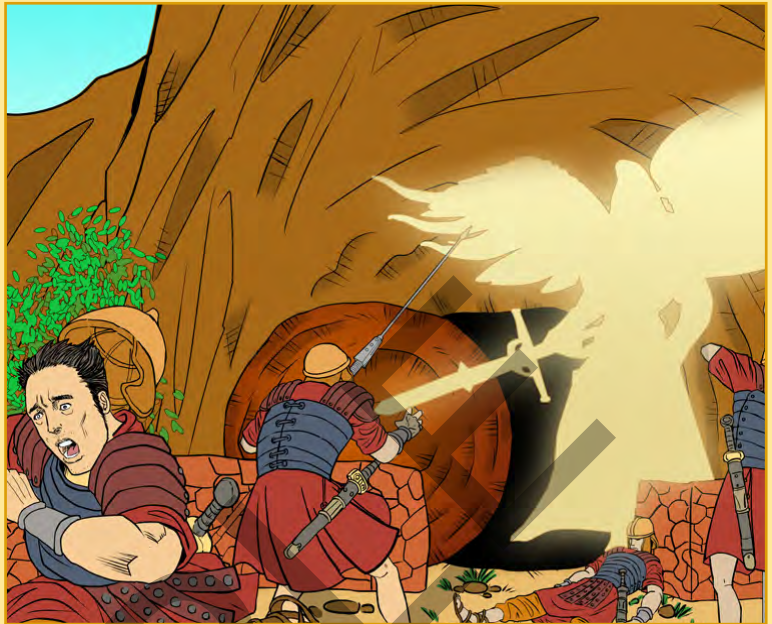

Lessons from Story:

1. The Jewish authorities request the Roman Governor to send a team of soldiers to seal and guard the tomb of Jesus. The team of soldiers would have prevented ordinary thieves or even the disciples from stealing the body of Jesus.
2. Jesus is raised from the dead on the third day after His crucifixion. There was a violent earthquake and the appearance of an angel.

Discover True or False

1. The Jewish authorities were afraid that Jesus's disciples would try to steal his body. True / False
2. The stone did not roll away. True / False
3. Thomas did not believe that Jesus has risen. True / False

The way to Jesus's Tomb

Colour the picture and find the way.

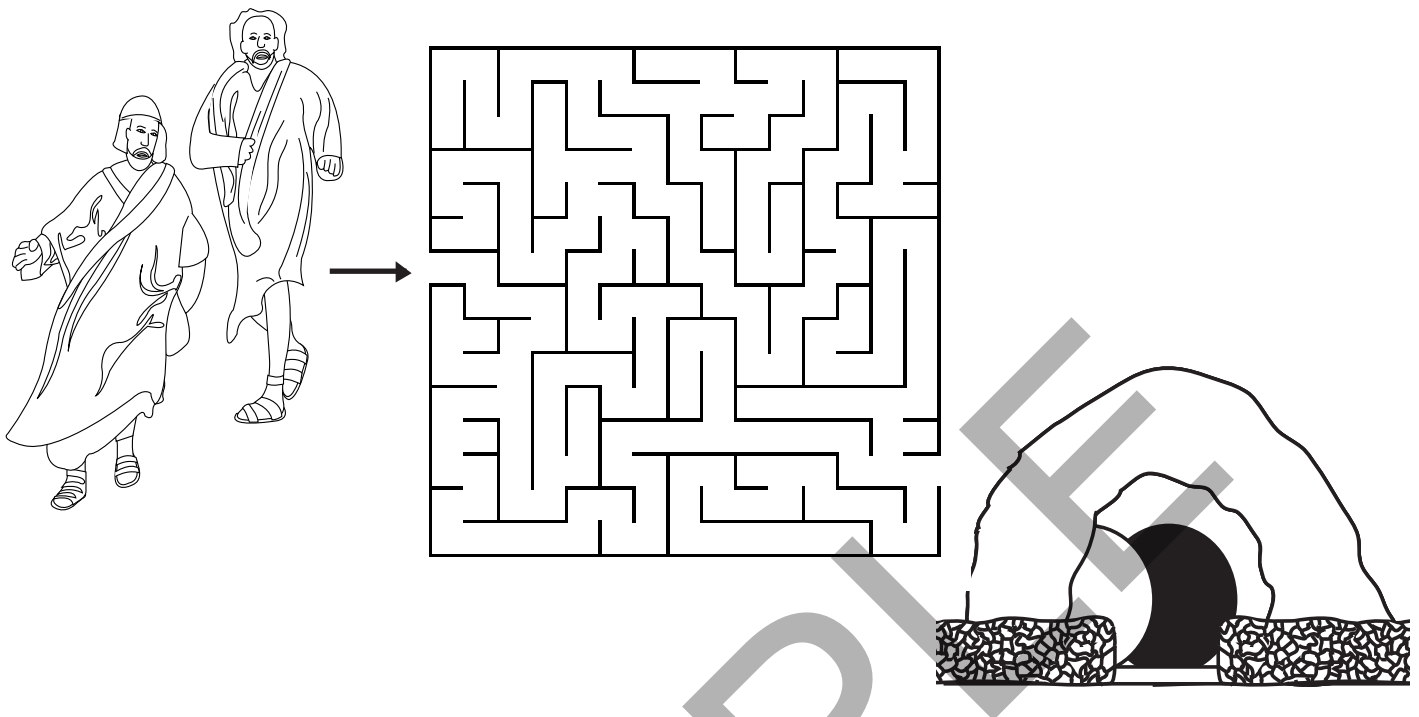

Respond

1. The Jewish authorities requested that Jesus' tomb be heavily guarded because they were afraid that the disciples would try to steal his body and tell people that Jesus has risen. Why were the Jewish authorities afraid of?

2. Why did Jesus say blessed are those who believe even without seeing Him?

Prayer

Dear God, thank you for raising Jesus from the dead. Now I'm believing in a God who is alive today!. In Jesus' Name, Amen.

The Gospel Story Vol. 2

Lesson 33: THE LAST BREAKFAST

Bible Truth: God loves us.

Objective: That the children will be assured that God loves them so much that He will always forgive them when they repent, no matter what they have done before.

Bible Reference:

John 21

Memory verse: “The Lord is compassionate and gracious, slow to anger, abounding in love.” Psalm 103:8



Lessons from Story:

1. Jesus lovingly restores Simon Peter as His disciple and the leader of His followers.
2. John explains the reason why he had recorded all the events.

Draw a comic to tell the story of Jesus asking Simon Peter if he loved Jesus.

--	--	--

Discover

The give words in the box

F	F	I	S	H	Z	U	S
K	I	L	P	U	Y	B	I
A	W	S	C	Y	M	C	E
D	X	P	H	A	Y	E	M
I	A	S	L	I	F	N	I
U	C	E	Y	B	N	X	H
Z	F	W	R	D	F	G	H
E	V	O	L	B	L	I	F

1. Some of the disciples were _____ when they saw Jesus.
2. Jesus and the disciples were eating _____ and _____
3. Jesus asked Simon Peter, "Do you _____ me?"
4. Jesus asked Simon to take care of his _____.

BREAD

FISH

FISHING

LAMBS

LOVE

Respond

1. How do you think Peter felt when Jesus asked him if he you loved Him three times?

2. When you have done things that are wrong, how do you feel when you talk to God? Do you think God will forgive you?

Prayer

Dear God, I'm sorry for _____. I ask for your forgiveness. In Jesus' Name, Amen.

The Gospel Story Vol. 2

Lesson 34: THE GREAT COMMISSION

Bible Truth: To witness to others what Jesus has done and teach people to become His disciples.

Objective: That the children will take to heart Jesus' command to witness to others about what Jesus has done for them.

Bible Reference:

Matthew 28:11-20; Luke 24:44-53;
Acts 1:10-11; Luke 1:1-4

Memory verse: "Therefore go and make disciples of all nations, baptizing them in the name of the Father and of the Son and of the Holy Spirit, and teaching them to obey everything I have commanded you. And surely I am with you always, to the very end of the age." Matthew 28:19-20



Lessons from Story:

1. The Jewish authorities bribe the Roman guards to spread a false report that the disciples had stolen the body of Jesus and proclaiming His resurrection.
2. Jesus gives His disciples the Great Commission. They are to take the Good News of God's salvation to the whole world and make disciples of all who believe.
3. Jesus tells them to wait for the coming of the Holy Spirit who will guide and empower them as they take His message to the whole world.

Photostat, colour, cut and paste

Color the picture below, cut on the black lines, mix it and paste the puzzle together.

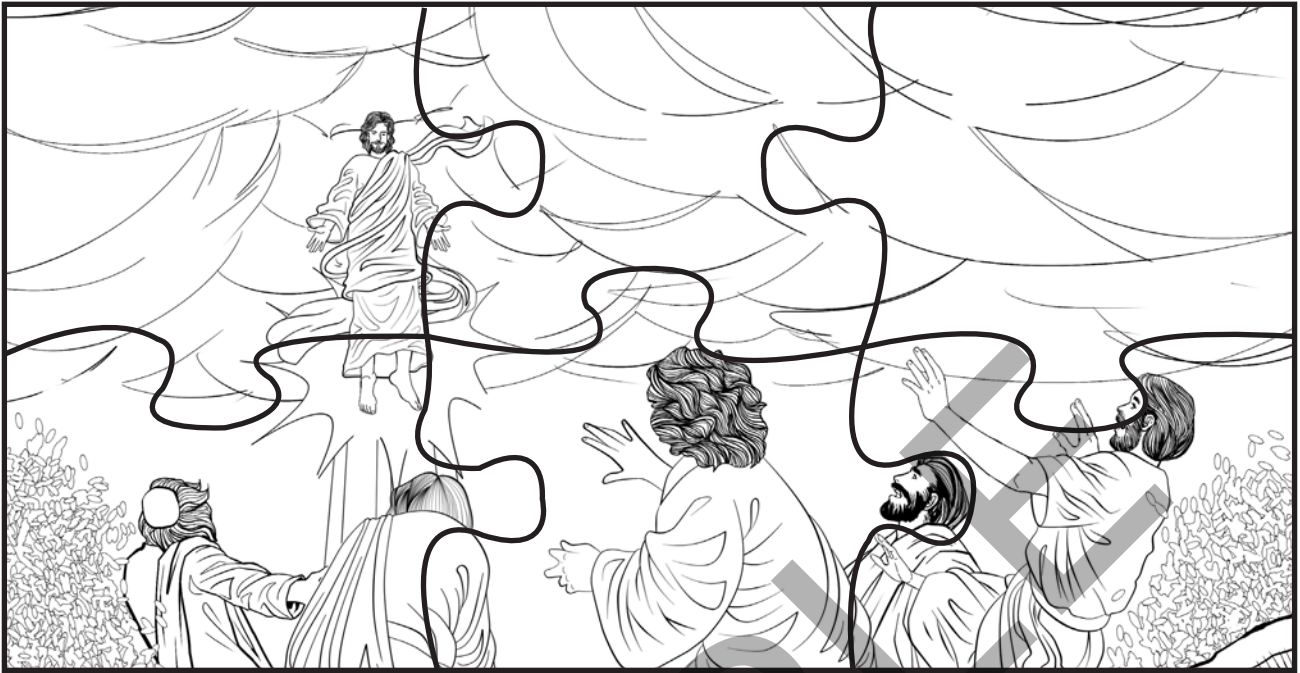

Respond

1. Write down the Great Commission from Matther 28:19-20

2. Jesus commands us to go make disciples. What does this mean?

3. How do we make disciples?

Prayer

Dear God, I'm sorry for _____. I ask for your forgiveness. In Jesus' Name, Amen.

SAMPLE

SAMPLE

The Visual Bible Explorer Series

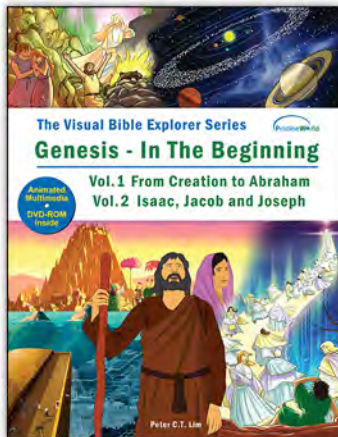

Genesis - In the Beginning

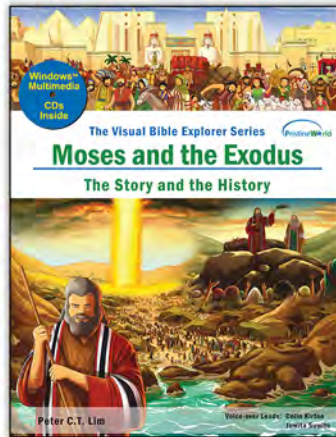

Moses and the Exodus

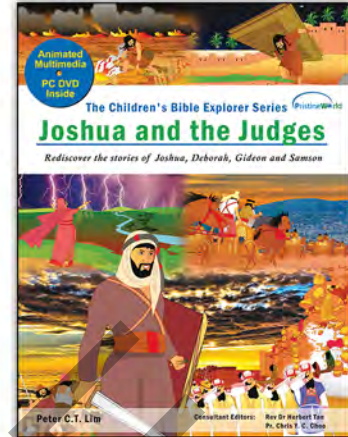

Joshua and the Judges

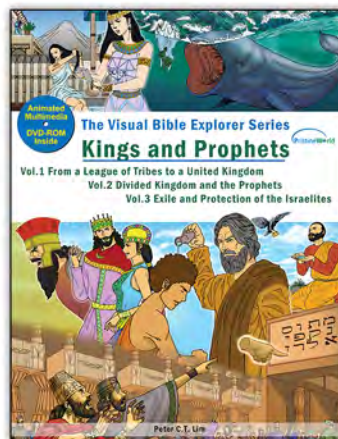

Kings and Prophets

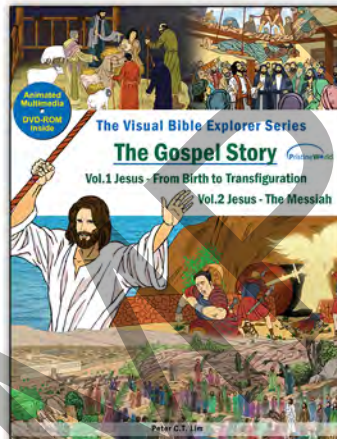

The Gospel Story

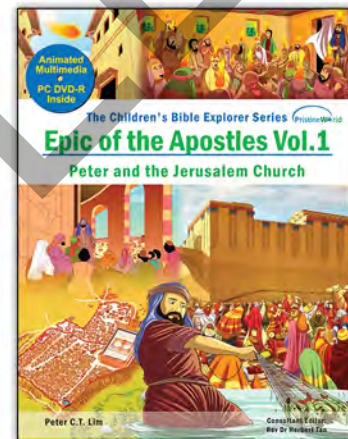

Epic of the Apostles Vol.1

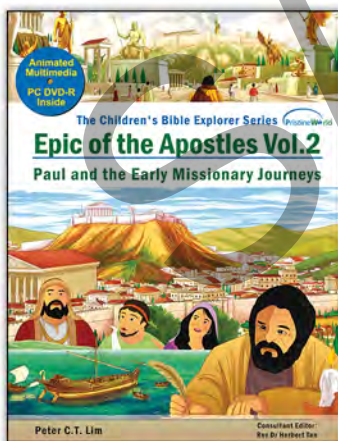

Epic of the Apostles Vol.2



Visit us at www.pristine-world.com
 For inquiries e-mail us at
pristineworld@gmail.com