

Student Workbook for The Visual Bible Explorer Series

Moses and the Exodus

Ages 9 - 10



SAMPLE

Student Workbook

Based on

Moses and the Exodus Ages 9 - 10

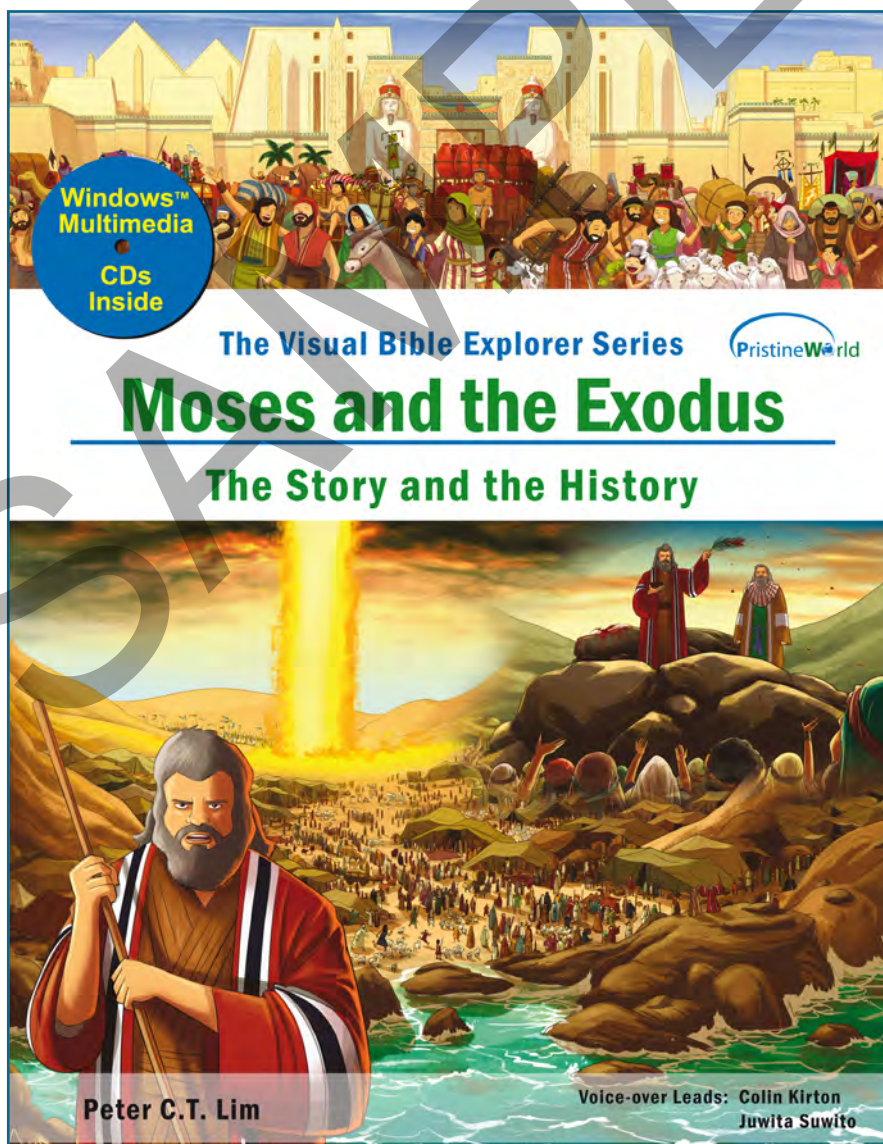

Revised Edition 2018

Copyrights



First published in Malaysia in 2018 by Pristine World Sdn Bhd
Copyright © 2009, 2018 Pristine World Sdn Bhd, Malaysia

All rights reserved. No part of this publication or multimedia may be reproduced, stored in a retrieval system or transmitted in any form or by any means, electronic, mechanical, photocopying, recording, scanning or otherwise, without the prior written permission of the copyright owner.

Scripture taken from the **HOLY BIBLE, NEW INTERNATIONAL VERSION®**.
Copyright © 1973, 1978, 1984 by International Bible Society. Used by permission of Zondervan Publishing House. All rights reserved.

The “NIV” and “New International Version” trademarks are registered in the United States Patent and Trademark Office by International Bible Society. Use of either trademark requires the written permission of International Bible Society.

Acknowledgements

Pristine World would like to thank Jane Peris and Samantha Yong for taking time out to help develop the Student Workbooks for this series.

Both of them are experienced Sunday School teachers. In this revised edition, some supplementary material have been added by Peter C. T. Lim.

How to use the book

Using the Book as a Companion Book

This Student Workbook was designed as a companion book and therefore works best when used together with the multimedia book The Visual Bible Explorer Series – Moses and the Exodus’.

In a Bible class environment, the teacher can play the multimedia lesson by lesson and then break the class up according to their age groups. In their age group classes, the teacher can then use the workbook to re-emphasize a lesson that was taught in the multimedia.

Using the Book without the Multimedia

We understand that not all classes may have the benefit of the multimedia book. A Bible class can be conducted with the Student Workbook and a Bible. In such cases it would be especially important for someone to read aloud the given passage for the lesson. Quotations used in the workbook are taken from the New International Version ^(NIV).

Duration of each Lesson

We recommend that the teacher takes about 40 minutes, at least, to complete each lesson. However if the class cannot finish a lesson within their allotted time, they can continue or finish it in the following week. Ideally, it should be one lesson per week.

Journaling their responses

Ask the children to write their answers to the questions on the book itself. The book will then serve as a journal as they take this journey of discovery in their understanding of the Bible; but remind the children that the process requires learning as well as application.

May you all be richly blessed as you use The Visual Bible Explorer Series in learning and applying valuable lessons from the Bible.

Peter C. T. Lim
Director
Pristine World Sdn Bhd

Chronology of the Exodus Story

1. T-80 years	<ul style="list-style-type: none"> - 80 years before the Exodus – Egypt persecutes the Israelites and massacres their baby boys - Moses is born and adopted by an Egyptian princess
2. T-40 yrs	<ul style="list-style-type: none"> - Moses flees to Midian, marries Zipporah and becomes a shepherd
3. A few months before the Exodus	<ul style="list-style-type: none"> - God speaks to Moses from a burning bush - Moses and Aaron confront Pharaoh - The Ten plagues of Egypt begin
4. Exodus Day	<ul style="list-style-type: none"> - Midnight – The Tenth Plague strikes Egypt - Soon after midnight – Moses receives the order to bring his people out of Egypt
5. T + A Few days up to 40 days	<ul style="list-style-type: none"> - God parts the Red Sea to let His people escape. - The Egyptian army drown when they try to follow - 3 days after crossing the Red Sea – the Israelites arrive at Marah – place of bitter water - Later they arrive at Elim - Joshua leads Israel to battle the Amalekites at Rephidim
6. T + 50 days	<ul style="list-style-type: none"> - Israel camps at Mt Sinai and Moses receives the Ten Commandments - Israel makes a covenant with God - Aaron makes the Golden Calf and Israel breaks their covenant - There is a civil war in the camp and 3000 people are killed - Moses receives the second set of Stone Tablets and renews the Covenant
7. T + a few months	<ul style="list-style-type: none"> - Israel sends 12 spies to the Promised Land - Based on their report, Israel rebels against Moses and refuses to enter the Promised Land - God punishes Israel
8. T + 39 years	<ul style="list-style-type: none"> - Miriam dies at Kadesh - Later Aaron dies and is buried at Mt Hor - God uses a donkey to teach Balaam a lesson. Later Balaam pronounces a blessing on Israel and a curse on Moab
9. T + 40 years	<ul style="list-style-type: none"> - Moses passes the leadership of Israel to Joshua - Moses dies at the summit of Mt Nebo overlooking the Promised Land - Israel is poised, ready to enter the Promised Land

Notes:

T – Represents the Exodus Day

Moses and the Exodus

Contents

Lesson 1	Introduction to Moses and the Exodus	6
Lesson 2	Persecution of the Israelites and the Birth of Moses	8
Lesson 3	Moses and the Burning Bush	10
Lesson 4	The Confrontation with Pharaoh	12
Lesson 5	The First Nine Plagues of Egypt	14
Lesson 6	The Last Plague & the Passover	16
Lesson 7	The Exodus	18
Lesson 8	Bitter Water in a Hot Desert	20
Lesson 9	Love the Lord Your God	22
Lesson 10	Love your Neighbour as Yourself	24
Lesson 11	The Lord Makes a Covenant with Israel	26
Lesson 12	Israel makes a Tabernacle for God	28
Lesson 13	The Golden Calf	30
Lesson 14	The Rebellion of the Spies	32
Lesson 15	The Waters of Meribah and the Bronze snake	34
Lesson 16	Aaron and Miriam	36
Lesson 17	Balak, Balaam and the Donkey	40
Lesson 18	Moses and Joshua	42
Lesson 19	Life of Moses	44
Lesson 20	Review Lessons	46
	Figures for cutting & making 3-D model	48
	Notes	62

Lesson 1: INTRODUCTION TO MOSES AND THE EXODUS

Theme: God's promise to His people.

Lesson Aim: To know that God loves His people and always keeps His promises.

Bible Reference: Ex 6:6-8

Verse to Ponder: Ex 6:8 And I will bring you to the land I swore with uplifted hand to give to Abraham, to Isaac & to Jacob...



Learn

Key Lessons

1. God keeps His promise, He rescues his people from slavery. His plans for his people are always good plans.
2. God gives his people a set of laws to help them live good lives.

Notes on Book of Exodus

(Fill in the blanks with the following words)

all, record, free, Moses, Pharaoh, 80, Goshen, Joshua, Aaron, ten, 430, going out, Miriam, slaves

1. Exodus was written to _____ the events of Israel's deliverance from Egypt and to see how it grew as a nation.
2. _____ wrote the book of Exodus.
3. Exodus was written for the people of Israel and then to _____ believers.
4. The place is Egypt where God's people were _____ but God set them _____.
5. The key people that are in Exodus are: Moses, Miriam, _____, Pharaoh's daughter and Aaron.

6. Key places to remember are Egypt, _____, Nile River, Midian, Red Sea, Mount Sinai.
7. This book is famous for the _____ commandments.
8. Exodus means the _____.
9. The Israelites were slaves for about _____ years.
10. Moses was _____ years old when he lead the Israelites out of Egypt.
11. Who is the brother of Moses? _____
12. Who is the sister of Moses? _____

How can we apply what we have learnt here?

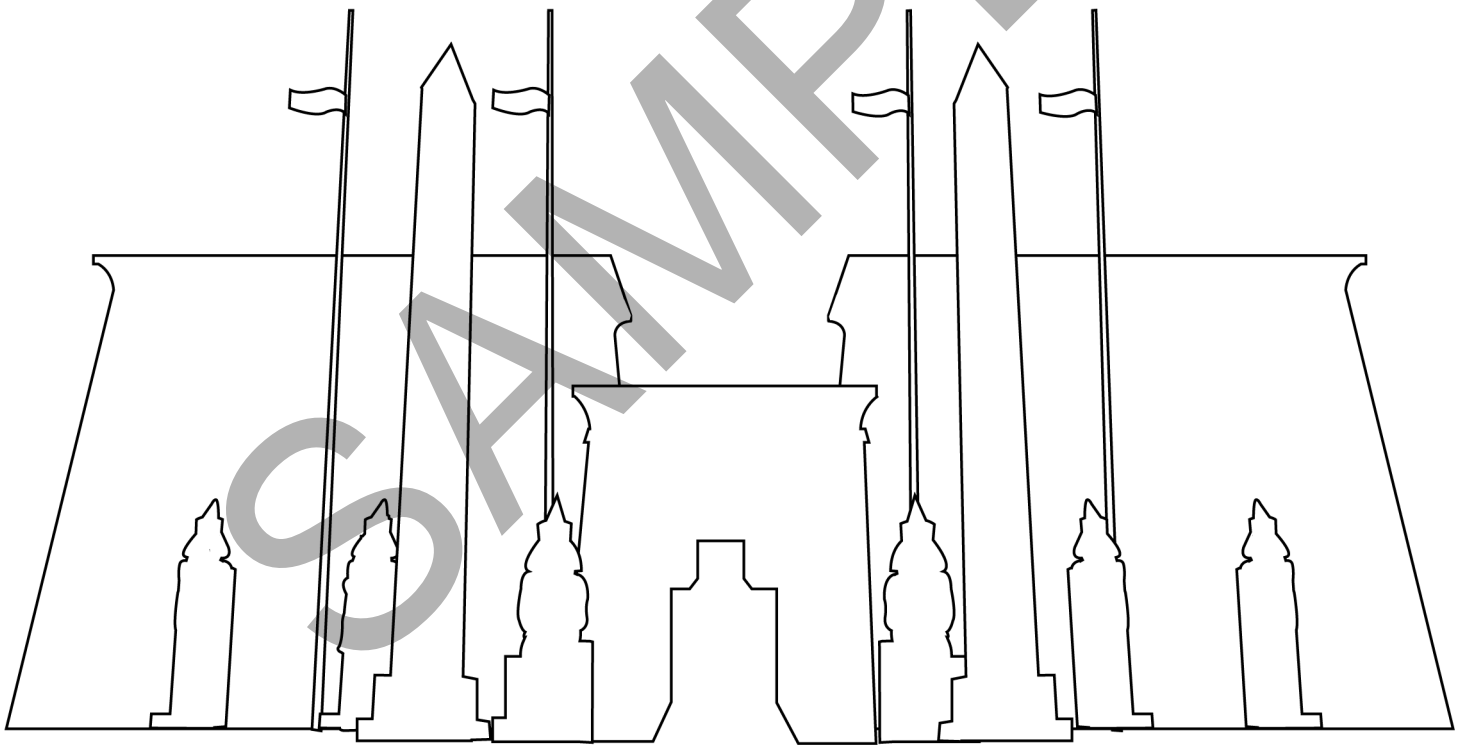

APPLICATION:

God is good and He keeps every promise He makes to his people (including you and I). Like for instance, He promises to love us, to care, to protect and to help us with problems that we cannot handle. We only have to trust and obey Him.

Lesson 2: PERSECUTION OF THE ISRAELITES AND THE BIRTH OF MOSES

Theme: God is in control

Lesson Aim: To know that God sees everything and is in control.

Bible Reference:

Ex 1:1-22

Verse to Ponder: Ex 1:20 So God was kind to the midwives and the people increased and became even more numerous.



Learn

Key Lessons

1. The Israelites are growing in numbers. This worries Pharaoh. He makes them suffer as slaves and even tries to destroy them. The Lord protects the Israelites.
2. Moses is rescued and brought up by Pharaoh's daughter. This is God's way of protecting and preparing Moses for an important task in the future.

Quiz

1. About how many years have passed from the time when Jacob and his family came to Egypt until the birth of Moses? (Ex 12:40)
 - a. 300 years
 - b. 500 years
 - c. 400 years
2. Where did the Hebrew people settle in Egypt? (Ex 9:26)
 - a. Midian
 - b. Goshen
 - c. Rameses
3. How did Pharaoh try to control the population of the Israelites? (Ex 1:8-16)
 - a. by asking the midwives to kill all newborn baby boys
 - b. by making them work very hard as slaves
 - c. All of the above
4. Name the cities that the slaves help build for Pharaoh. (Ex 1:11)
 - a. Pithom and Gaza
 - b. Gaza and Rameses
 - c. Pithom and Rameses
5. Every boy that is born must be thrown into the Nile. (Ex 1:22)
 - a. True
 - b. False

Quiz Match the correct number on the () given with the number on the answers.

1. Who were the parents of Moses? ()
2. Name the brother and sister of Moses. ()
3. Moses was put in a papyrus basket by his mother. What did she use to make the basket waterproof? ()
4. Pharaoh's daughter found baby Moses and decided to () the baby for herself.
5. Who nursed baby Moses for the Pharaoh's daughter? ()
6. Pharaoh's daughter named the baby she rescued 'Moses' because ().
7. Moses's mother sent him on a little voyage. What kind of transport did he use? ()

Answers

1. Aaron & Miriam
2. Tar & Pitch
3. Keep
4. Amran & Jochebed
5. Papyrus basket
6. She drew him from the water
7. Jochebed

Activity Corner

Find the following hidden things in the picture:

bread, a pyramid, cup, locust, frog and Pharaoh



APPLICATION:

1. Why didn't the midwives obey Pharaoh's orders to kill the baby boys?
Read Ex 20:13 – it tells us that _____
Read Ex 1:17 – it tells us that the midwives _____
2. If you were asked to do some thing bad, what would you do?

3. Why do you think Pharaoh's daughter disobeyed her father's order? Read Ex 2:6 - _____
4. When was the last time you did something courageous?
5. God is in control. Although God allowed His people to be persecuted at this time by the Egyptians, He still watched over them and caused them to grow or increase in number. God is sovereign.

Do you know that God is watching over you?

Yes No

Lesson 3: MOSES AND THE BURNING BUSH

Theme: God prepares Moses for the mission

Lesson Aim: To know that God prepares us for His work.

Bible Reference: Ex 2:11-25, Exodus 3:1-4:17

Verse to Ponder: Exodus 2:24
God heard their groaning and He remembered His covenant with Abraham, with Isaac and with Jacob



Learn

Key Lessons

1. God promised to free the Israelites and give them a land of their own.
2. Although Moses lived in the palace and was an Egyptian prince, he identifies with the Israelites. He sees their suffering and feels for them.

Observation Questions

1. How old was Moses when he killed the Egyptian task master?
2. What did Moses do when he realised that his killing of an Egyptian had become known, even to Pharaoh?
3. Who did Moses marry and what was her occupation?
4. What job did Moses take up after he got married?
5. What was unusual about the burning bush?
6. How did God introduce Himself to Moses?

7. What did God say He was going to do and why?

8. Write down the excuses that Moses made and what was God's solution for each of those excuses.

Moses's Excuse	God's reply

**APPLICATION:
The 'Wilderness'
(from Hero to
Zero) experience**

1. Moses was brought up as a Prince of Egypt for 40 years. He spent the next 40 years as a shepherd in the 'wilderness' of Midian. Why do you think God allowed Moses to go through this experience? Are you facing any difficult situations now or recently? In what ways can you see God working in your life so far?

**Activity Corner: Find the words listed below
in the Word Search**

Staff, Moses, Aaron,
snake, Pharaoh, Israel,
Nile, Sinai, shepherd

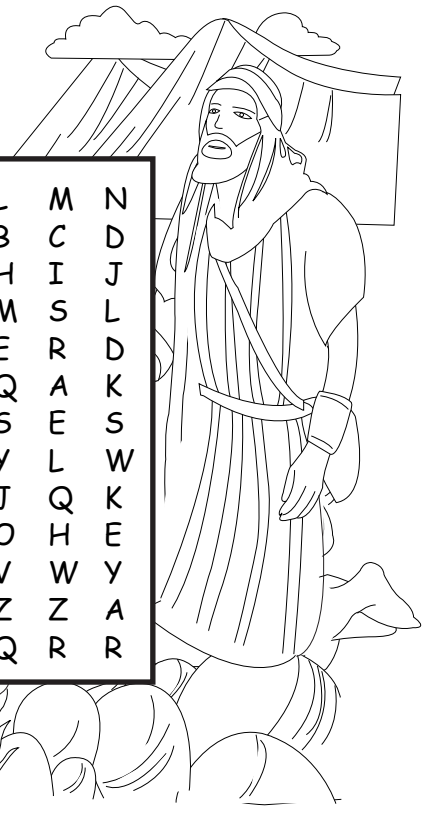

Lesson 4: MOSES CONFRONTS PHARAOH

Theme: God is with Moses all the time

Lesson Aim: To know that God will help us when we ask Him.

Bible Reference:
Ex 4:16-20, Ex 5:1-9, 6:1-10,
7:1-13

Verse to Ponder: Ex 4:21 The LORD said to Moses, 'When you return to Egypt, see that you perform before Pharaoh all the wonders I have given you power to do....'



Learn

Key Lessons

At first the Israelites believed what Moses tells them. But when they receive greater oppression from Pharaoh, they were quick to turn their anger on Moses.

Observation Questions

1. Who did Moses and Aaron meet and talk to first and what was their response? (Ex 4:29-30)
2. How did Pharaoh respond when Moses and Aaron first met him to ask for the release of the Israelites and what was the reason he gave? (Ex 5:1-4)
3. What did Pharaoh do to the Israelites after listening to Moses and Aaron? (Ex 5:6-14)
4. When the Israelite overseers went and appealed to Pharaoh, what did Pharaoh say? (Ex 5:17-18)
5. Who did the Israelite overseers blame and what did they say?

6. What did Moses do then?

7. Describe the battle of the snakes (Exodus 7:10-13) and its impact on Pharaoh.

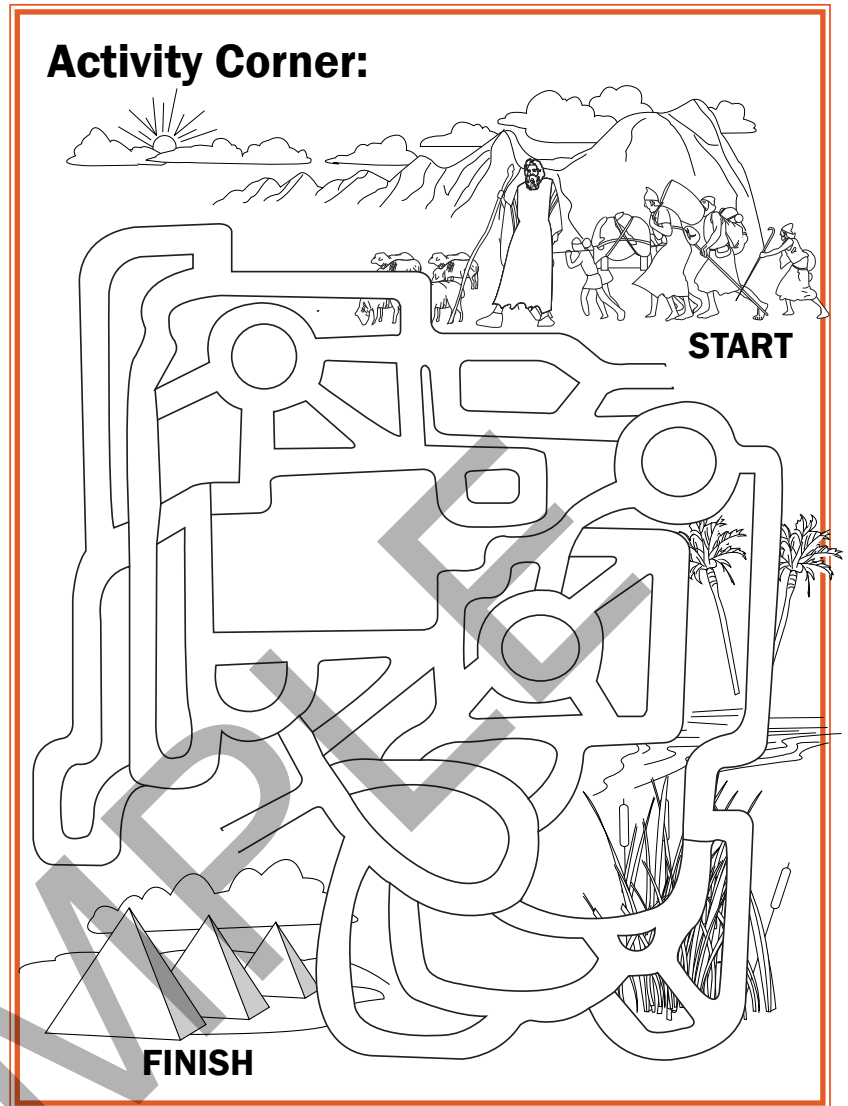

APPLICATION:

1. Can you share a discouragement that you have faced when you tried to do something good but people misunderstood your actions as something bad or your well-intended actions did not have good results and people blamed you for the bad results.

Lesson 5: THE FIRST NINE PLAGUES OF EGYPT

Theme: God uses Pharaoh's stubbornness

Lesson Aim: To know that the God of Moses & Israel is the true God - more powerful than all the other gods

Bible Reference:
Ex 7:14-9:7

Verse to Ponder:
Ex 7:14 Then the Lord said to Moses, "Pharaoh's heart is unyielding; he refuses to let the people go."



Learn

Key Lessons

God uses Pharaoh's stubbornness to bring about a series of plagues. The gods of Egypt could not help them.

Plague of gnats	The waters of the Nile turned to blood
Goshen	The 1st and 2nd plagues only

1. What was the first plague to hit Egypt? (Ex 7:17) _____
2. The magicians tried to imitate the plagues. Which plagues could they imitate? (Ex 7:11 & Ex 8:7) _____
3. Which plague was also named the finger of God? (Ex 8:19)

Draw an arrow to the correct number for the order of the Plagues. (The first 5 plagues.)

	Bible Ref.	Plague No.
The plague of Gnat	Exodus 8:16-19	_____
The plague of Flies	Exodus 8:20-30	_____
The plague of blood	Exodus 7:14-24	_____
The plague of livestock	Exodus 9:1-7	_____
The plague of Frogs	Exodus 8:2-15	_____

Activity Corner: Find the words listed below in the Word Search - The Next 5 plagues

BOILS
LOCUSTS
DEATH ANGEL
HAIL
DARKNESS

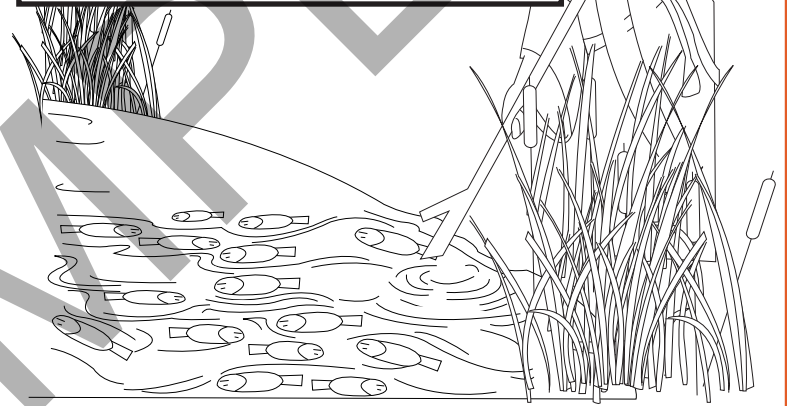
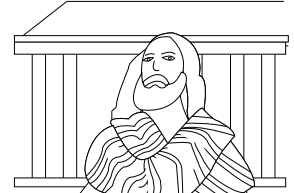

APPLICATION:

God's word must be obeyed, otherwise there is punishment. God desires for us to repent. Just like the story here, it is not so much that God wanted to punish the people 9 times, but rather, He has given them (Pharoah) 9 chances to repent.

When we do something wrong, we must repent and admit our wrong doings before God. Do you have something that you need to repent before God? If so, say it to Him in your prayer.

Lesson 6: THE LAST PLAGUE AND THE PASSOVER

Theme: God made a way for His people

Lesson Aim: To know that God has made a way for all of us to be saved.

Bible Reference:
Ex 10:24-12:30

Verse to Ponder: Ex 12:27 then tell them, 'it's the Passover sacrifice to the LORD, who passed over the houses of the Israelites in Egypt and spared our homes....'



Learn

Key Lessons

1. Pharaoh was given many chances to change his mind. He refused and brought disaster to himself and his people.
2. In the New Testament, Jesus used this event to show how He would become the Passover Lamb that was sacrificed for our sins.

Quiz

1. After the plague of darkness what did Pharaoh say to Moses? (Ex 11:24)
 - a. You can all go but leave your flocks and herds behind
 - b. Please go quickly and take whatever you want.
2. What were the Israelites to do on the night of the Passover? (Ref to the story)
 - a. Stay indoor and wear your traveling clothes ready to travel
 - b. Eat meat roasted over fire and bread without yeast
 - c. Slaughter a lamb, take some of its blood and put it on the side and tops of their door frames
 - d. All of the above
3. After the firstborn of Egypt has been struck down, what did Pharaoh say to Moses? (Ex 12:31-32)
 - a. You can all go and worship your God and ask your God to bless me also
 - b. You can all go but please do not come back
4. What time did the avenging angel of the Lord strike Egypt? (Ex 11:4)
 - a. Dawn
 - b. Midnight

Lesson 7: THE EXODUS



Theme: God guided Moses each step of the way

Lesson Aim: To know that God is with us through our daily walk with Him

Bible Reference: Ex 12:31-42; Ex 13:17-22; Ex 14:1-31

Verse to Ponder: Ex 13:12 By day the LORD went ahead of them in a pillar of cloud to guide them on their way and by night in a pillar of fire to give them light, so that they could travel by day or night.

Learn

Key Lessons

1. The Lord proved to His people that He is God.
2. The Lord confirms that Moses is His appointed leader. He speaks through Moses and performs great signs and wonders through him.

Quiz

1. Why did Moses take the bones of Joseph along with them? (Ex 13:19)

2. When the Israelites left Egypt, they took the longer route around the desert toward the Red Sea because _____ (Ex 13:17)
3. Where did Pharaoh's army find the Israelites encamped at? _____ (Ex 14:9)
4. When Jacob entered Egypt to escape the famine in Canaan, how many people did he take with him? _____ (Ex 1:5)
5. How did the Lord lead the Israelites during the day time? _____ (Ex 13:21)
6. How did God lead the Israelites during the night? _____ (Ex 13:21)

7. Where was the starting point of the Exodus? _____ (Ex 12:37)
8. How many men on foot journeyed from Rameses to Succoth? _____ (Ex12:37)
9. The _____ prevented the Egyptian army from attacking the Israelites immediately? (Ex 14:19-20)
10. The Israelites _____ Moses when saw the Egyptian army approaching them. (Ex 14:10-12)
11. In Ex 14: 13-14, Moses's answer to the people was, " _____".
12. The Lord drove the sea back with a _____. (Ex 14:21)
13. At _____ the divided sea went back to its place (Ex 14:27)
14. The _____ of Pharaoh died when the waters covered them. (Ex 14:28)

APPLICATION:

God performed mighty miracles to protect and rescue His people. These miracles have been recorded in the Bible so that we can read about it and believe that our God is great. How can we show our faith in God in our everyday life?

How often do you read the Bible?

- Everyday
- Once a week
- when I feel like it.

What else can I do?

Activity Corner: Use this example to write out Ex 14:14 The Lord will fight for you, you need only to be still. Decipher the words bellow by removing the letter 'Q'.

QTQQQQQHQQ

QLQQQRQDQ

QWQQQQIQLQLQ

QFQQIQGQHQT

QFQQQQRQ

QYQQOQQUQQQ

Lesson 8: FOOD, WATER AND WAR

Theme: God provides

Lesson Aim: To know that God is our provider.

Bible Reference: Ex 15:22-27, Ex 16:1-23 and Ex 17:1-17

Verse to Ponder: Ex 16:4 Then the LORD said to Moses, "I will rain down bread from heaven for you..."



Learn

Key Lessons

1. The Lord teaches the Israelites that He is their Provider.
2. The Lord not only provides food and water. He protects them from the enemy.

True or False

True	False	Moses led them to the Desert of Shur after they crossed the Red Sea. (Ex 15:22)
True	False	The people travelled without food for 3 days and nights before they came to Marah. (Ex 15:22)
True	False	The water in Marah was too salty to drink. (Ex 15:23)
True	False	To make the water become sweet Moses did the rain dance. (Ex 15:25)
True	False	When they came to Elim, the people found 12 springs & 70 palm trees. (Ex 15:27)
True	False	The Desert of Sin was located between Elim and Sinai. (Ex 16:1)
True	False	The Israelites set out from Elim on the 15th day of the 2nd month after they left Egypt. (Ex 16:1)
True	False	The Lord gave them quail and manna meat in place of bread when His people grumbled because there was not enough food. (Ex 16:13)

Fill the blanks with the the correct answer

Joshua, The Amalekites, Rephidim, The Lord is my Banner,
Aaron and Hur, the rock at Horeb

1. At _____ the people complained to Moses when they had very little water (Ex 17:1)
2. _____ were the first enemies to attack the Israelites after they had crossed the Red Sea. (Ex 17:8)
3. Moses called _____ to lead the Israelites in battle against the Amalekites. (Ex 17:9)
4. _____ helped to hold up the hands of Moses while Joshua battled with the Amalekites. (Ex 17:12)
5. God told Moses to strike _____, so that they will get water. (Ex 17:6)
6. Moses built an altar and called it _____. (Ex 17:15)

APPLICATION:

1. The Israelites had seen how powerful God is and how He fulfills promises and yet when they faced difficulties they did not trust Him to lead them. They thought He had deserted them. If you were in the same shoes as the Israelites, walking through the desert with very little food; no Mc D or nasi lemak stall in sight, what would you do?

2. Why do you think the Lord led Moses and Joshua to defeat the Amalekites in such an unusual way?

Lesson 9: LOVE THE LORD YOUR GOD



Theme: God gives us a set of laws

Lesson Aim: To know that God has given us commandments on how to live our lives.

Bible Reference: Ex 19:1-8, Ex 20:1-11

Verse to Ponder: Ex 19:5 Now if you obey me fully and keep my covenant, then out of all nations you will be my treasured possession...

Learn

Key Lessons

1. God protects His people from dangers in the desert wilderness.
2. The first set of commandments teaches His people to Love Him (God) and how He expects them to relate to Him.

1. Match the correct verse with the sentence

1. Now if you obey me fully and keep my covenant, then out of all nations you will be my treasured possession	Ex 19:17
2. The Lord said to Moses, "I am going to come to you in a dense cloud, so that the people will hear me speaking with you and will always put their trust in you..."	Ex 20:1&2
3. Then Moses led the people out of the camp to meet with God, and they stood at the foot of the mountain.	Ex 19:5
4. And God spoke all these words: "I am the Lord God, who brought you out of Egypt, out of the land of slavery..."	Ex 20:3
5. You shall have no other gods before me.	Ex 19:9

2. **Activities Corner:** Remove the Q, Y, X & Z from the letters to find out the hidden commandment.

L X Y Z O X X Q V Z Z X E
 T H Z Z E X Y Z Q Q Z Z
 L X X Z O Z Z R D X Q Q Z
 W I X Z Z T Q Y Z Z H Z Z Z
 A X Q Q Z Z X L L Z Q Q Z Z
 Y O X X Q Q U Z Z R Q Z
 H Y E A Q Q Z Z R Q T Z Z
 S Q Z Z Q Q X O X X Z U L Z Z
 & Z Z Q Q X Z X Q
 M Q Q X X X Z Z I N Z Q X D
 X & X X S T Q Q Z R E Q N G Z Z T H

3. Write down the first four commandments:

APPLICATION:

1. Remember the times when you first started school? Were you given rules? Do you think that rules or laws are necessary? Yes No

Why? _____

2. Which of the 10 commandments deal with our relationship with God and which ones deal with our relationship with each other?

3. The no.1 love in our lives must be God – that is His commandment. List down some of the things we can love more than God.

Eg. Money, _____

Lesson 10: LOVE YOUR NEIGHBOUR AS YOURSELF

Theme: God's way to live

Lesson Aim: To know that by using God's laws we can live well with others.

Bible Reference: Ex 20:12-17

Verse to Ponder:

Ex 20:12 Honor your father and mother, so that you may live long in the land the Lord your God is giving you.



Copyright © Pristine World

Learn

Key Lessons

The next set of Commandments tells the people how God expects His people to relate with other people.

1. True or False

True	False	The first commandment, which has a promise at the end is 'You shall honor your father and mother' (Ex 20:12)
True	False	God gave them laws that showed them how to treat each other's property? (Ex 22)
True	False	God gave them laws that showed them how to treat slaves? (Ex 21)
True	False	God gave them laws to show them how to keep idols? (Ex 23:24)
True	False	God promised His people protection from sicknesses and enemies, a good and large country if they would only worship and obey His laws. (Ex 23:20-30)
True	False	God's people rejected the covenant because they knew they could not keep the 10 commandments. (Ex 24:7)

2. Write down commandments No.5 to No.10

(Questions for Discussion and Application)

3. Is it difficult for you to keep the 5th commandment “Honor your father and mother”? Why?

4. Is it wrong to desire to steal something that belongs to another person? Why?

APPLICATION:

1. How did Jesus summarise the Law? Refer to Mark 12:28-31. Based on what Jesus said about the Law, summarise in your own words the objective of the Ten Commandments. _____

2. The Bible tells us that God is holy and hates sin. Sin keeps us from having a good relationship with Him. How do we make sure that this does not happen to us?

Lesson 11: THE LORD MAKES A COVENANT WITH ISRAEL

Theme: God's covenant with Israel

Lesson Aim: To know that God has a set law on how to live and worship Him.

Bible Reference:
Ex 24:1-14; Ex 25:8-22

Verse to Ponder: Ex 24:3 When Moses went and told the people all the LORD's words and laws, they responded with one voice, "Everything the LORD has said we will do."



Learn

Key Lessons

God gave his people laws and instructions on how to worship Him so that they can continue to enjoy living under His protection.

Use the Bible reference given to find the correct answers.

Ark, 12, tabernacle, 40 days and 40 nights, Mount Sinai, 70 of the elders

1. Moses brought with him _____ of Israel to worship the Lord at the mountain. (Ex 24:1)
2. Moses got gifts of gold & silver, yarn & fine linen, acacia wood & beautiful gemstones from the people to help make the _____. (Ex 25:3)
3. Moses built up an altar and set up _____ stone pillars – one representing each tribe of Israel. (Ex 24:4)
4. Moses went up on top of _____ to receive the stone tablets with the 10 commandments written on them. (Ex 24:12)
5. The _____ was to be made of Acacia wood and overlaid with gold. (Ex 25:10-16)
6. Moses stayed _____ on the mountain top. (Ex 24:18)

7. Write down 1 key point of the covenant that the people were making with God.

Activity Corner: (Unscramble these letters)

tcabenrale _____ ogld _____ kra _____

wodo _____ motunain _____

cnoveant _____ atrla _____

APPLICATION:

1. The Covenant was needed for man to have fellowship with God. Christians believe Jesus paid the price of our sins by His death on the cross. He shed His blood for us. If we believe in our heart that Jesus died for our sins, and receive Him into our life to be our Lord, we can make a covenant with God.
2. Based on the New Testament, example in Romans 12:1-2 and 2 Corinthians 8:2-5, what kind of gifts do you think God would like His followers to give today?
3. How have you been faithful in giving according to your beliefs?

If Not, Why? _____

Lesson 12: ISRAEL MAKES A TABERNACLE FOR GOD

Theme: Worship of God

Lesson Aim: To know how we should worship God.

Bible Reference:
Ex 24 - Ex 27

Verse to Ponder:
Ex 25: 8 & 9 Then have them make a sanctuary for me, and I will dwell among them. Make this tabernacle and all its furnishing exactly like the pattern I will show you.



Learn

Key Lessons

God shows the Israelites how to worship Him in an orderly manner. In worshipping Him they would know of His character, His holiness, His love and His mercy.

Match the correct Bible reference to the questions

- The 3 symbols of the glory of God are cloud, fire and voice of God.
- The Menorah or Lamp stand was made of pure gold and had six branches extended from the sides.
- Special garments was made for Aaron and the priest to give them dignity and honor
- When the people wanted to make animal sacrifices they used a Bronze altar.
- All of the objects were to be placed inside a Courtyard.
- The place where God would dwell among them and meet with them was called Tent of Meeting.

	Ex 28:21
	Ex 33:7
	Ex 24:12-18
	Ex 27:1-3
	Ex 28:2
	Ex 25:31

7. The altar was built of acacia wood.
8. 12 stones – each to represent a tribe of Israel were on the Breastplate of Aaron. e, to be place inside a Courtyard.
9. Did the Israelites really need a special place (the tabernacle) to worship God when He is everywhere? Yes No
Why? _____

	Ex 27:1
	Ex 27:9

10. The Tabernacle
- was designed to be _____ It could be dismantled and carried around wherever the Israelites went. (fixed / mobile)
 - did not allow anyone into the _____ because of human sinfulness. (courtyard / Holy of Holies)

Activity Corner: There are 6 items listed here that was used to make the tabernacle.

Acacia wood yarn
gold silver
bronze

A	B	D	E	A	Y	H	Z	A	N	K	E	L
Q	R	X	M	N	A	S	G	O	L	D	N	O
R	P	T	B	V	R	H	X	W	Y	L	B	A
E	C	D	F	O	N	A	H	H	I	O	R	J
V	G	O	P	M	I	I	J	K	Z	C	O	B
L	F	E	T	S	M	L	K	L	V	U	N	W
I	D	A	R	K	N	E	S	S	O	S	Z	S
S	Q	R	S	M	N	P	Z	Z	V	T	E	B
B	C	V	W	W	S	A	B	C	D	S	E	T
A	C	A	C	I	A	W	O	O	D	J	H	U

OPTIONAL ACTIVITY: Use Figure 1 in the back of the book to make a 3-D paper model of the tabernacle.

APPLICATION:

1. Now the Israelites could worship God in the way it pleases Him. We too need to know that when we worship God, He is pleased. In what ways can we worship Him?

Lesson 13: THE GOLDEN CALF



Theme: To worship God only.

Lesson Aim: To know that we should only worship the Lord God and no other gods.

Bible Reference: Exodus 32:1-35; 34:1-5

Verse to Ponder: Ex 32:14 Then the Lord relented and did not bring on his people the disaster he had threatened.

Learn

Key Lessons

God will not tolerate His people worshipping idols or any other gods. They are to worship Him alone.

Questions

1. What did the Israelites ask Aaron to do when Moses was delayed in coming down from the mountain?
2. What was Aaron's reply to the peoples' request?
3. What did Aaron do after the people made their request?
4. When God saw what the people were doing, what did He say to Moses? (Exodus 32:7-10)
5. How did Moses plead with God to forgive the people?

6. What did Moses do when he saw the Golden Calf and the people dancing?

7. What excuse did Aaron give to Moses?

Activity Corner: Use Ex 32:18 for this activity.

Cross out all the letters that appear four times in the grid.

Then write the leftover letters on the lines below to spell out two words to complete the verse.

X	X	X	X	Z
D	Z	Z	C	A
Z	E	Q	Q	Q
J	J	S	K	J
K	W	K	K	L
H	H	T	J	F
R	V	V	O	V
H	Q	H	V	Y
W	W	E	D	W

Moses _____ the golden _____

Activity Corner: Complete the crossword using the vocabulary words.

	³ R				T				S
² I			⁵ T	¹ A					
				G					
			⁴ R		B				

Clues:

1. extreme displeasure.
2. an image used as an object of worship
3. morally right, law-abiding
4. a person who fights against, resist
5. a flat slab of stone

APPLICATION:

1. Describe the excuses that Aaron gave in Exodus 32:21-24. How are we in danger of making similar excuses when we are tempted or pressured to do something we know is wrong?

Lesson 14: THE REBELLION OF THE SPIES

Theme: Faith in God

Lesson Aim: To know that when we have faith in God, great things happen.

Bible Reference:
Numbers 13:1-2, 16-33, 14:1-38

Verse to Ponder:
Numbers 13:30 Then Caleb silenced the people before Moses and said, "we should go up and take possession of the land, for we can certainly do it."



Learn

Key Lessons

1. God punished the Israelites by not letting them conquer the Promised Land.
2. God spared Joshua and Caleb because of their faith in Him.

Answer the question by using the bible reference

Caleb, Valley of Eshcol, 12, milk and honey, 40 days, Israelites, ancestral tribe,

1. God instructed Moses to send one leader from each _____ to explore the land of Canaan. (Numbers 13:1-2)
2. All together _____ spies were to be sent to Canaan? (Numbers 13:4-15)
3. It is from the _____ that they cut off a cluster of grapes and carried it on a pole. (Numbers 13:23)
4. The spies spent _____ going through the land. (Numbers 13:25)
5. When asked to give a report of their findings, their first response was it does flow with _____. Here is its fruit. (Numbers 13:27)

6. It was _____ who silenced the people before Moses and said, “ We should go up and take possession of the land, for we can certainly do it.” (Numbers 13:30)
7. “The people there are like giants and are fearsome. Let’s not go in,” said the _____ to Moses? (Numbers 13:31-33)

Activity Corner:

Follow the day of the week through the maze.

S	U	N	D	Y	D	A	Y	A	D
U	N	O	Y	E	S	H	T	T	I
D	D	A	M	N	R	U	S	F	R
Y	M	Y	E	D	S	R	S	Y	I
N	O	Y	W	Y	Y	D	D	A	D
D	D	A	D	A	Y	A	T	Y	A
A	Y	T	S	R	F	T	A	S	Y
U	T	U	E	I	D	U	R	D	A
D	A	Y	A	D	A	Y	S	D	Y

APPLICATION:

1. One of life’s greatest wonders is this: because God loves you, He forgives again and again. But remember, you can be forgiven for making a bad choice, but that choice still has its consequences.

What is the consequence of the Israelites’ rebellion when they refused to attack Canaan? (Num 14:1-4). How can this lesson help us?

2. Joshua and Caleb could see the big picture - God was with them. They have seen how God protected and fought for them in the past. They knew God wanted them to go in, conquer and inhabit the land. They were also courageous. No doubt, battle with these nations would not be easy. But with God on their side, who could stop them? They put their trust in the Lord.

We can be like Joshua and Caleb. Tell God in the prayer below about the times when you needed courage to do the things that pleased Him.

Lesson 15: THE WATERS OF MERIBAH AND THE BRONZE SNAKE

Theme: God punishes Moses

Lesson Aim: To know that the law of God applies to everyone.

Bible Reference:
Numbers 20:1-13; 22-29; 21:1-18

Verse to Ponder:

Ex 20:12 The Lord said to Moses and Aaron "Because you did not trust in me enough to honor me as holy in the sight of the Israelites, you will not bring this community into the land I give them."

Learn

Key Lessons

Moses and Aaron were punished for their lack of trust. The Law of God applies to all.

True or False

True	False	Miriam, the sister of Moses, died at Desert of Zin at Kadesh. (Numbers 20:1)
True	False	The Lord punished Moses & Aaron at the waters of Meribah. (Numbers 20:12)
True	False	Lord punished Moses and Aaron at the waters of Meribah because they did not pray enough. (Numbers 20:12)
True	False	At Meribah the Lord ask Moses to speak to the rock for water. (Numbers 20:26)
True	False	Eleazar took over the role of Aaron after he died. (Numbers 20:28)
True	False	Aaron died at Mt. Hor. (Numbers 20:27-28)

Quiz Multiple Choice Questions

- Which Canaanite king wanted to attack the Israelites? (Numbers 21:1)
 - King of Jerusalem
 - King of Amalekites
 - King of Arad
- What did Israel do before they fought with the king of Arad? (Numbers 21:2)
 - Fasted and prayed
 - Prayed and made a vow to the Lord
 - Nothing
- God listened to the Israelites' plea. (Numbers 21:3)
 - True
 - False

4. What did the Israelites complain about this time? (Numbers 21:5)
 - A. There is no bread and water
 - B. We detest this food!
 - C. All of the above

5. What plague did the Lord send the Israelites? (Numbers 21:6)
 - A. Venomous spiders
 - B. Aedes mosquitoes
 - C. venomous snakes

6. What did the Lord tell Moses to do when he prayed for them? (Numbers 21:8)
 - A. Make a burnt offering
 - B. Stay still
 - C. Make a bronze snake on a pole for the people to see

7. How do you think Moses felt when the people started to complain again?

8. What was the 'sin' that Moses committed that made God punish him by not allowing him to enter the Promised Land?

Activity Corner: Word Finder
using the following words:

Meribah, water, rock,
 speak, trust, Eleazar,
 Kadesh, Aaron

K	K	O	I	E	J	G	L	D	S	J	S	R	O	C	K
K	A	K	J	D	A	S	G	I	A	J	G	D	S	D	
F	D	J	S	D	J	G	O	I	S	G	A	S	J	G	D
T	E	S	D	J	G	O	E	I	R	P	R	J	G	E	R
J	S	O	I	E	W	H	L	K	D	G	E	D	S	G	L
F	H	O	A	A	G	A	A	I	J	D	G	A	J	U	A
R	A	E	T	I	E	B	G	J	P	A	P	O	K	G	E
G	A	E	J	A	P	I	I	G	S	P	O	E	O	E	R
Q	R	T	J	L	F	R	S	J	T	R	U	S	T	R	A
F	G	J	P	E	O	E	J	P	S	O	G	P	O	D	Z
G	J	P	O	A	J	M	G	S	J	K	G	D	O	T	A
G	P	O	D	S	G	O	P	F	G	P	O	F	I	D	E
D	S	O	I	A	J	G	P	D	O	A	G	D	S	A	L
G	O	A	A	R	O	N	O	G	S	P	D	G	L	K	E

APPLICATION:

1. We can sometimes be like the grumbling Israelites, right? But do you know that when we grumble and criticize others, we are actually moving away from God! God does not like us to have that kind of attitude or spirit living in us.

What do you and your friends often criticize or grumble about?

2. Read John 3:15-17 Why did Jesus use this story to illustrate what He was about to do on the cross? Write down your thoughts.

Lesson 16: AARON AND MIRIAM

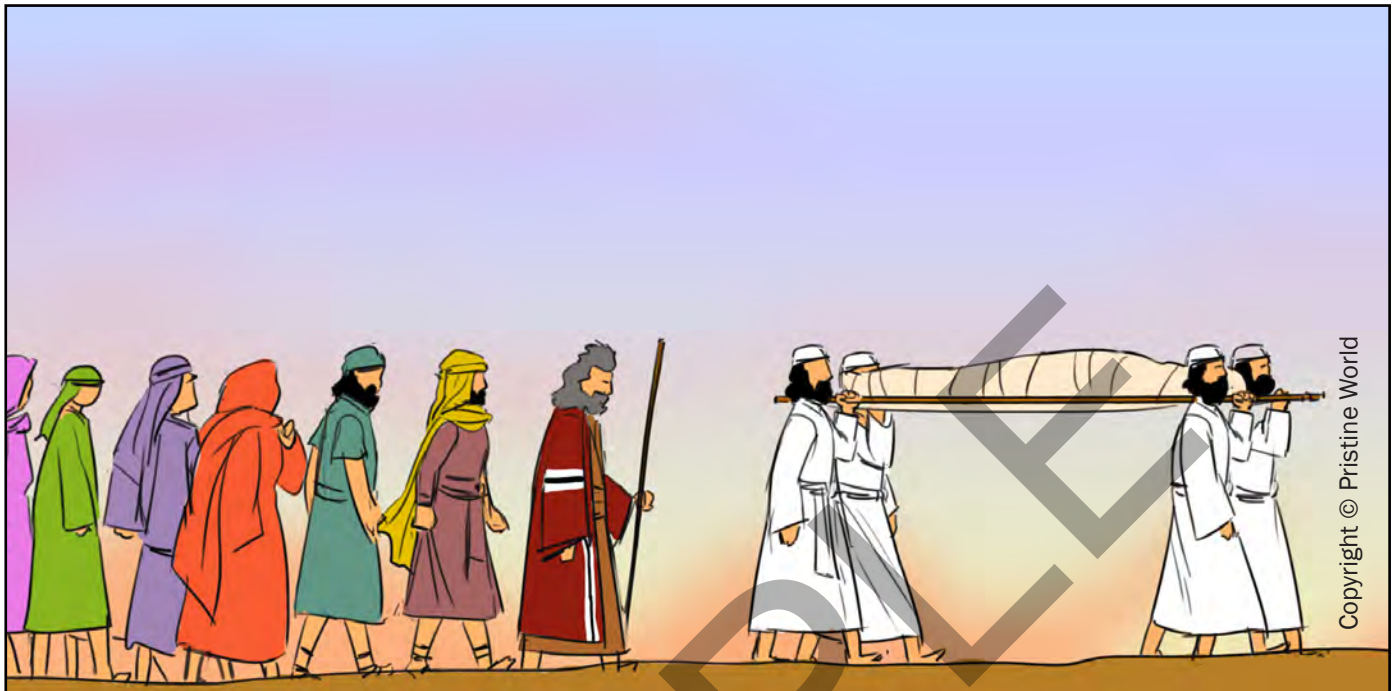

Project

Form groups of 4 or 5. Then each group to sub-divide to two groups. One group to do a study and presentation on the life and character of Miriam and the other on the life and character of Aaron.

Miriam and Aaron were the sister and brother of Moses.

A. *Miriam*

Look up Bible verses of Miriam and create a one page newspaper article that tells of her life story just after her death. Events of Miriam's life to highlight:

- The birth of Moses and the role Miriam played
- After crossing the Red Sea
- The Song of Miriam
- The prophetess
- Miriam's complaints against Moses
- Imaginary interviews with Moses and/or Aaron and friends of Miriam
- Her faith, strengths and weaknesses

Sample Newspaper (but student can create own format)

tabernacle tribune

Picture of Miriam

Headlines and Main Story

Quick Biodata

What else was happening

Imaginary interviews with other key characters, including Moses

B. Aaron

Look up Bible verses of all events and references to Aaron, the brother of Moses.

Create a one page newspaper article that tells of his life achievements, his strengths and weaknesses. Write it as a report just after his death.

Key points to consider:

- His accompanying Moses when they confronted Pharaoh
- Going with Moses and selected elders to the mountain
- Taking on the role of High Priest
- His complaints against Moses
- His role in the golden calf incident
- What happened at the waters of Meribah
- Imaginary interviews with Moses and friends of Aaron
- His faith, strengths and weaknesses

SAMPLE

Sample Newspaper (but student can create own format)

tabernacle times

Headline new - what happened

Pic drawing of Aaron

What else was happening

Interview with Moses

Imaginary Interviews with other Key Characters

Lesson 17: BALAK, BALAAM AND THE DONKEY

Theme: God's power

Lesson Aim: To know that God has the power to make donkeys talk.

Bible Reference: Numbers 22:1-13.

Verse to Ponder: Numbers 22:12 But God said to Balaam, "Do not go with them. You must not put a curse on those people, because they are blessed."

Learn

Key Lessons

1. Balaam is famous for his powerful words and curses. God uses a donkey, a 'stupid' animal to teach Balaam some lessons.
2. Balaam blesses Israel publicly.

Using the verse given, look up the answer in the Bible.

1. Numbers 22:4 - Who was the king of Moab?

2. Numbers 22:6 - What did King Balak ask Balaam to do?

3. Numbers 22:23-27 - Why did the donkey jump and dropped Balaam to the ground?

4. Numbers 24:17-19 - Balaam prophesied that Israel would do something to Moab in the future. What did he say?

5. Numbers 22:33 - What did the angel tell Balaam he would have done if the donkey had not turned away from him three times?

6. Which was easier for God - to make a donkey talk or to help his people understand and obey his commands in the Bible? Why?

Refer to Figure 2 (Lesson 17). Colour, cut & paste the pictures and write down who fell off the donkey and why.

SAMPLE

APPLICATION:

1. Balaam talked with God, heard from God, and gave true prophecies. But he had some problems; he was proud of his gift, and even worse, he loved money and was willing to do wrong to get rich. Have you ever wanted something so badly that you were tempted to do wrong just to get it?

Yes / No and why: _____

2. What can you learn from this story about God's love for his people?

Lesson 18: MOSES AND JOSHUA

Theme: God's chosen leaders

Lesson Aim: To know that God gave his people good leaders.

Bible Reference:
Deuteronomy 31:1-13

Verse to Ponder:
Deuteronomy 31:12 Assemble the people.. so that they can listen and learn to fear the Lord your God and follow carefully all the words of this law.



Learn

Key Lessons

1. Moses taught the Israelites to obey Gods' laws.
2. Moses carefully records down the laws of God.
3. Moses instructs the people to diligently teach their children the laws.
4. Moses and the leaders of Israel commissioned Joshua as the new leader.

Questions

Read Deuteronomy 31:1-13

1. How old was Moses at this time?
2. Who did Moses say would lead the Israelites into the Promised Land?
3. Who will divide the land among the tribes of Israel?
4. Who wrote down the Law and to whom was it entrusted to?

Read Deuteronomy 6:20-25

5. What was the promise if they kept the Law?

6. How did Moses show the people that Joshua was the chosen successor?

Read Deuteronomy 34

7. Where did Moses finally die and how old was he then?

8. How did Moses prepare Joshua to be the new leader?

Activity Corner: Use the table to decode the sentence below:

✌ A or F	Ω R or H	Ⓜ E or K	Ω N or Z	♏ I or P
♄ T or D	γ O or V	≡ S or F	✋ U or L	er J or G
& O or W	● M or X	○ B or Y		

APPLICATION:

1. If you knew that you were going to do a task or that an important responsibility was going to be passed to you, what would you do to prepare yourself?

1. ● γ ≡ Ⓜ ≡

2. ♄ Ω Ⓜ

3. ≡ Ⓜ Ω γ ✌ Ω ♄

4. γ ≡

5. er γ ♄

2. How would you put God in this process of preparing yourself?

Lesson 19: LIFE OF MOSES

Prepare a summary of the life of Moses in an imaginary newspaper article. The newspaper article should cover some of the major events in the life of Moses:

- a. Birth
- b. Upbringing as a prince of Egypt
- c. Flight to Midian
- d. The Call of Moses
- e. His struggles with Pharaoh as well as his own people
- f. The miracles performed through Moses
- g. His legacy
- h. What do we learn from the life of Moses

SAMPLE

Sample Newspaper (but student can create own format)

tabernacle times

Drawing of Moses

Headlines

Moses is dead!

Bio data of Moses

Summary Highlights of the life of Moses

Imaginary Interviews

Lesson 20: REVIEW LESSONS

Theme: God kept His promise to His people

Lesson Aim: To know that God used Moses and Joshua to lead His people to the land that He promised them.

Bible Reference:
Exodus, Numbers & Deuteronomy

Verse to Ponder:
Ex 6:8 And I will bring you the land I swore with uplifted hand to give to Abraham, to Isaac and to Jacob...



Review the lessons you have studied by listing down some of the important points.

Key Events

- _____
- _____
- _____
- _____
- _____

Key characteristics of God

- _____
- _____
- _____
- _____
- _____

Key characteristics of Moses

- | | |
|---------|---------|
| • _____ | • _____ |
| • _____ | • _____ |
| • _____ | • _____ |

How do the lessons from Exodus relate to your life now?

Exodus	Now
The Passover Event: _____ _____ _____	Jesus our Passover Lamb: _____ _____ _____
Tabernacle: _____ _____ _____	God is holy: _____ _____ _____

APPLICATION:

1. How can we apply the lessons we have learned from this book into our daily lives today. What are the applications for today?

2. All through Exodus, Numbers and Deuteronomy, we learned about God's character and how He used Moses and Joshua to fulfill the promise He made to Abraham, Isaac and Jacob. The people of Israel had to go through many challenges and difficulties; some were due to their own sin of grumbling and their lack of faith in God. Some were to show how great God is and what He can do for his people.

Why did God go through all this trouble for His people?

Write in your own words the lessons you have learnt from this study of Exodus.

Figure 1

Cutaway 3-D Paper Model of the Tabernacle.

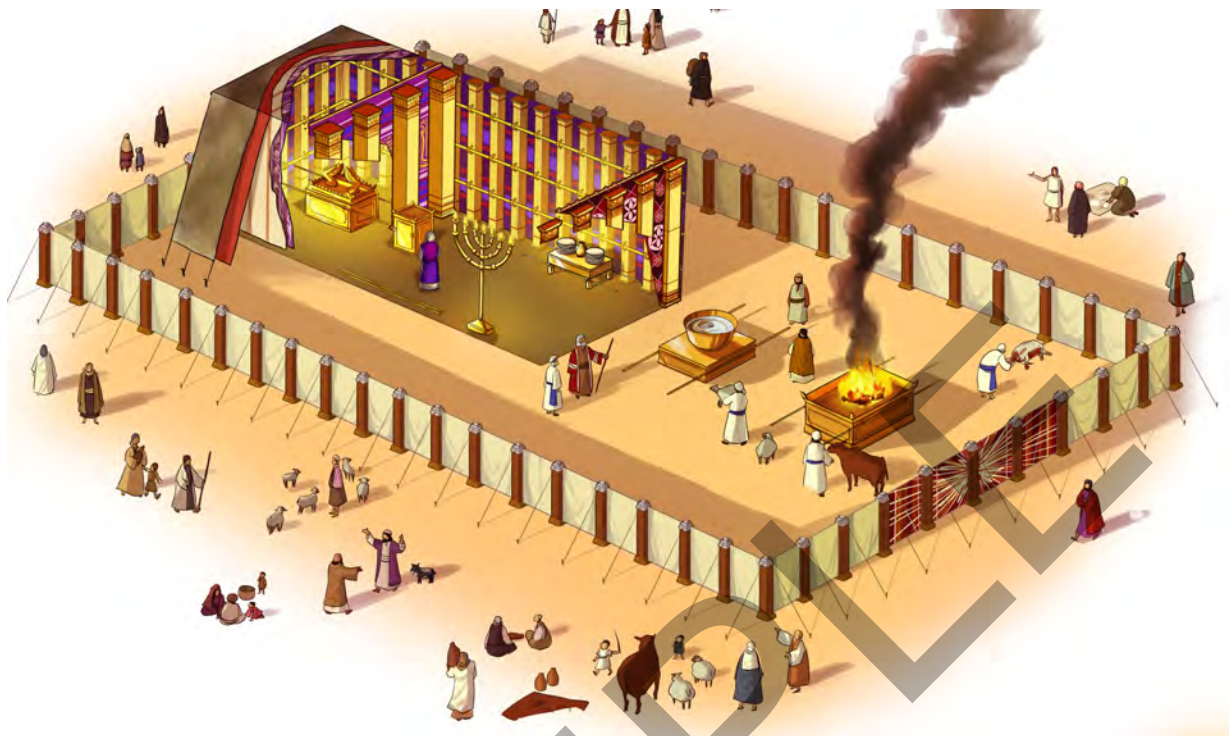

SAMPLE

SAMPLE

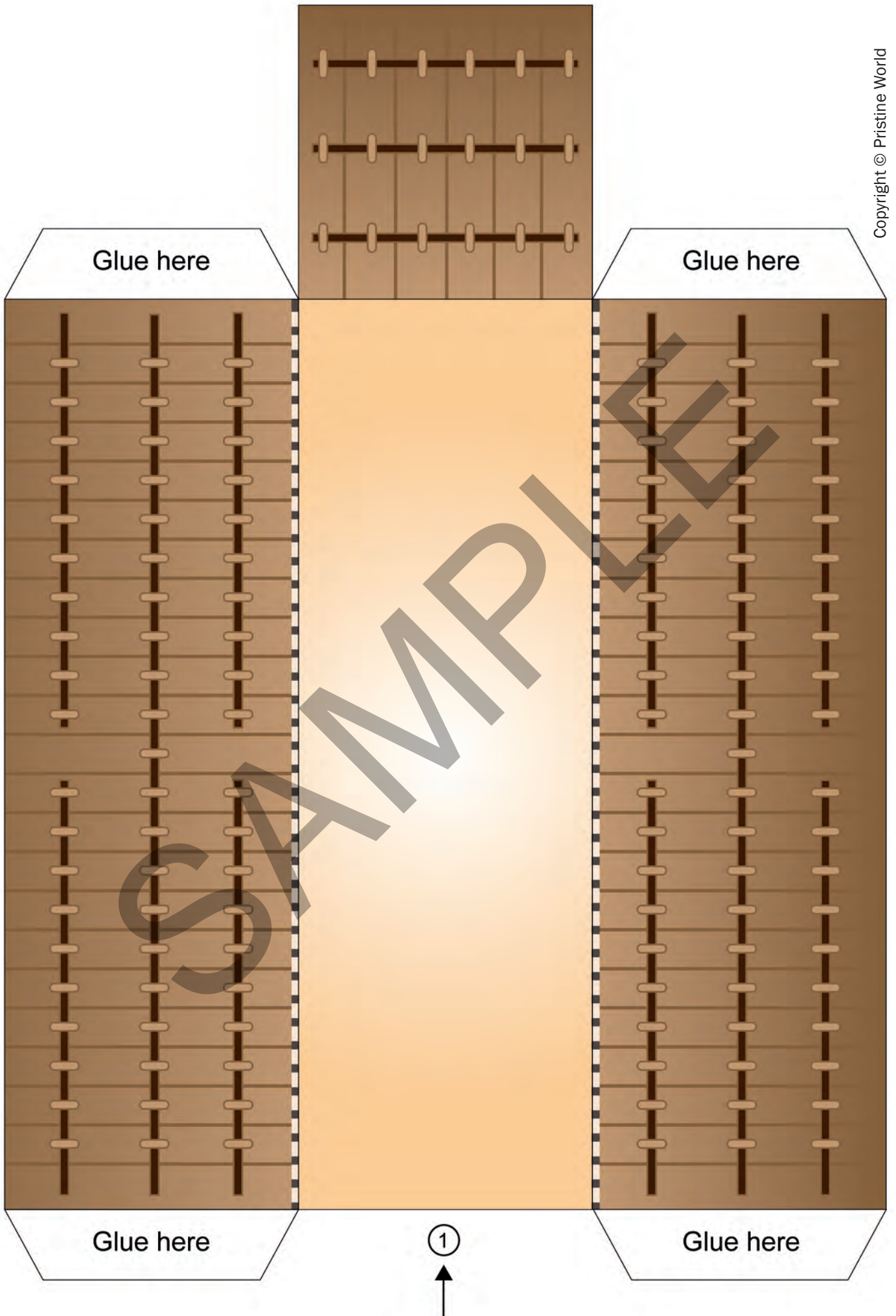

SAMPLE

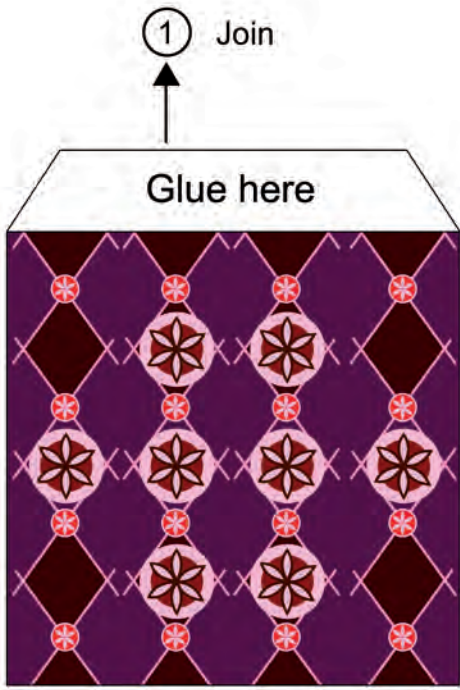

Copyright © Pristine World

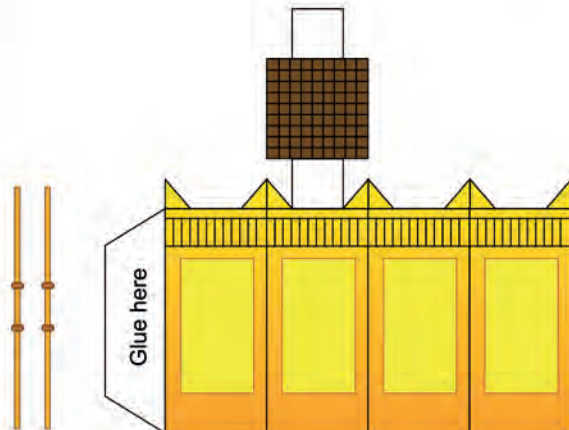
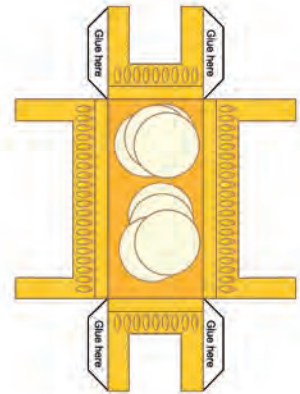
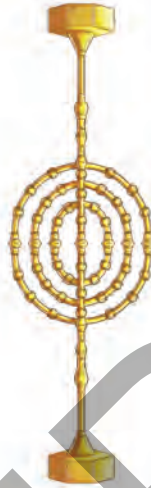
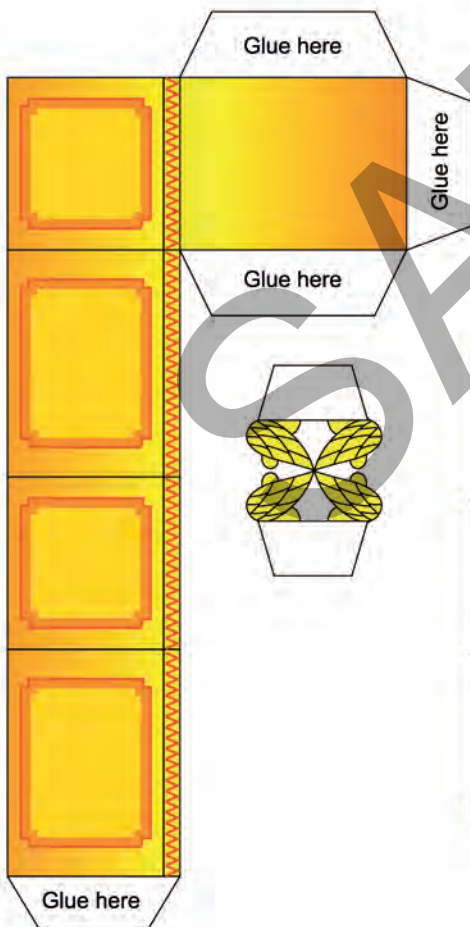
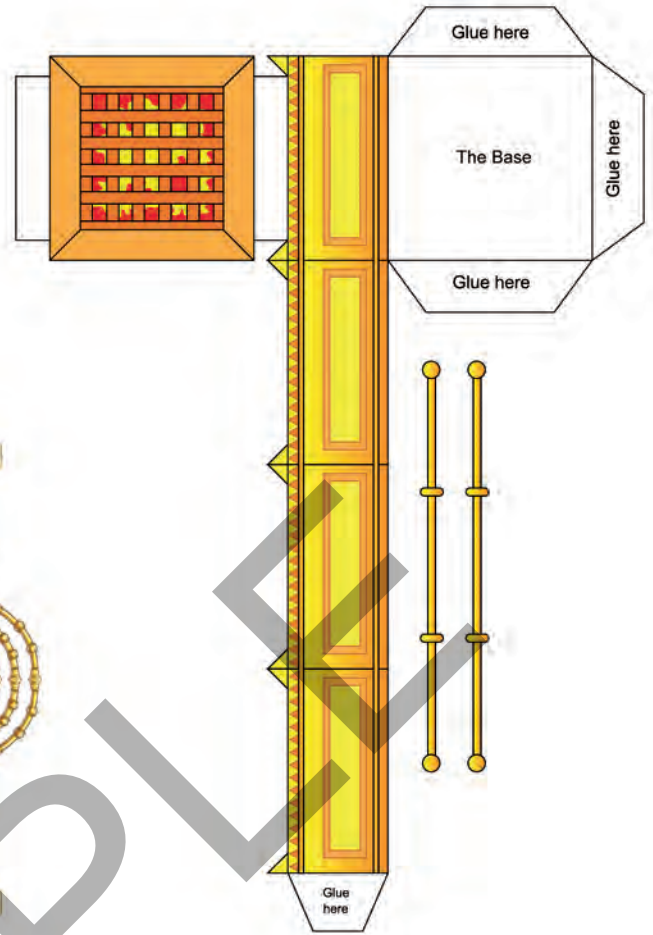

SAMPLE

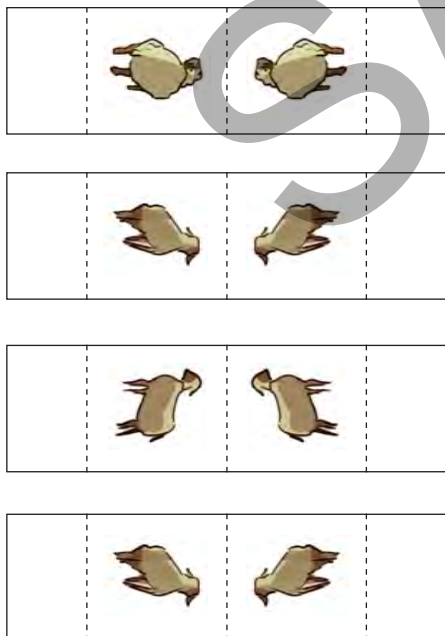
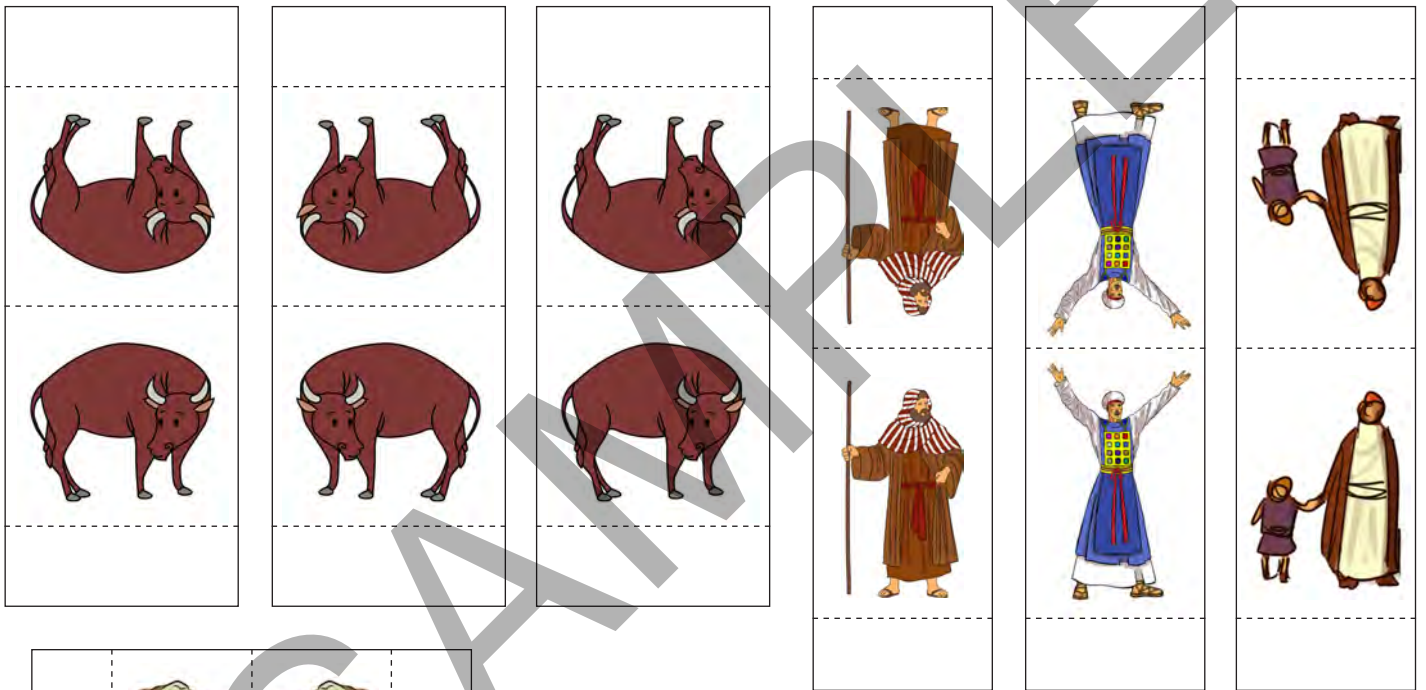
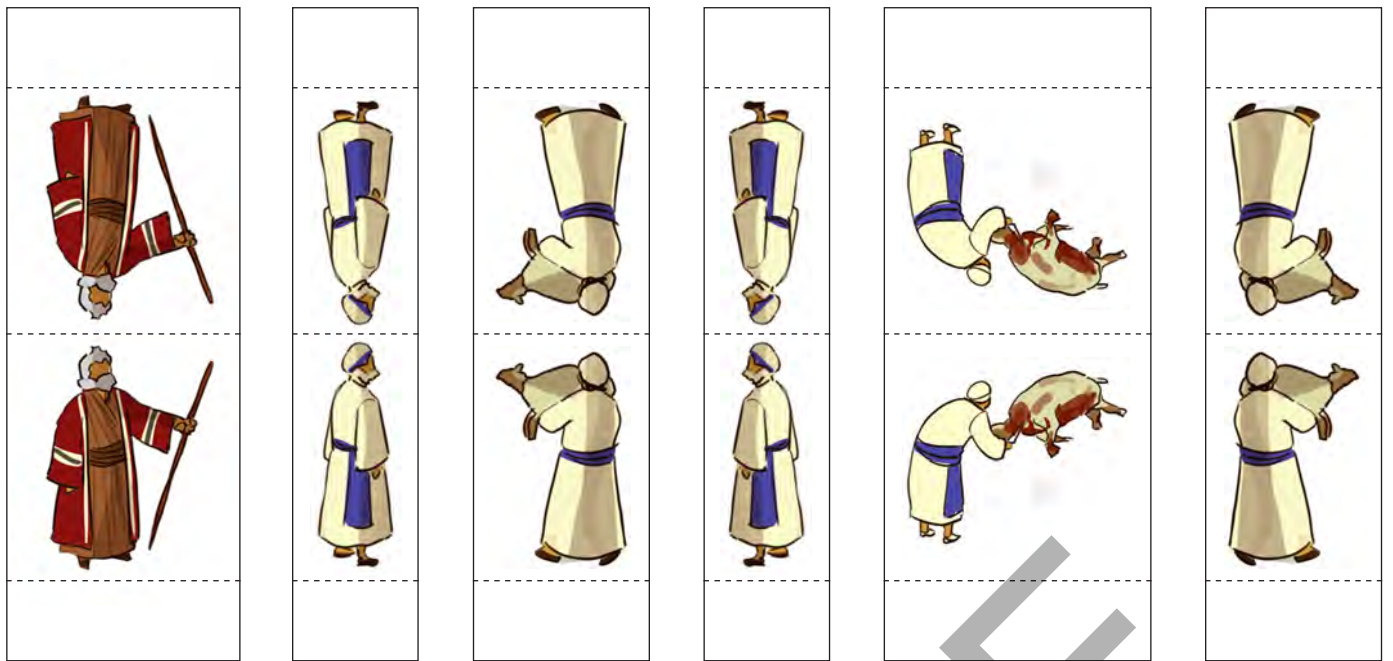

SAMPLE

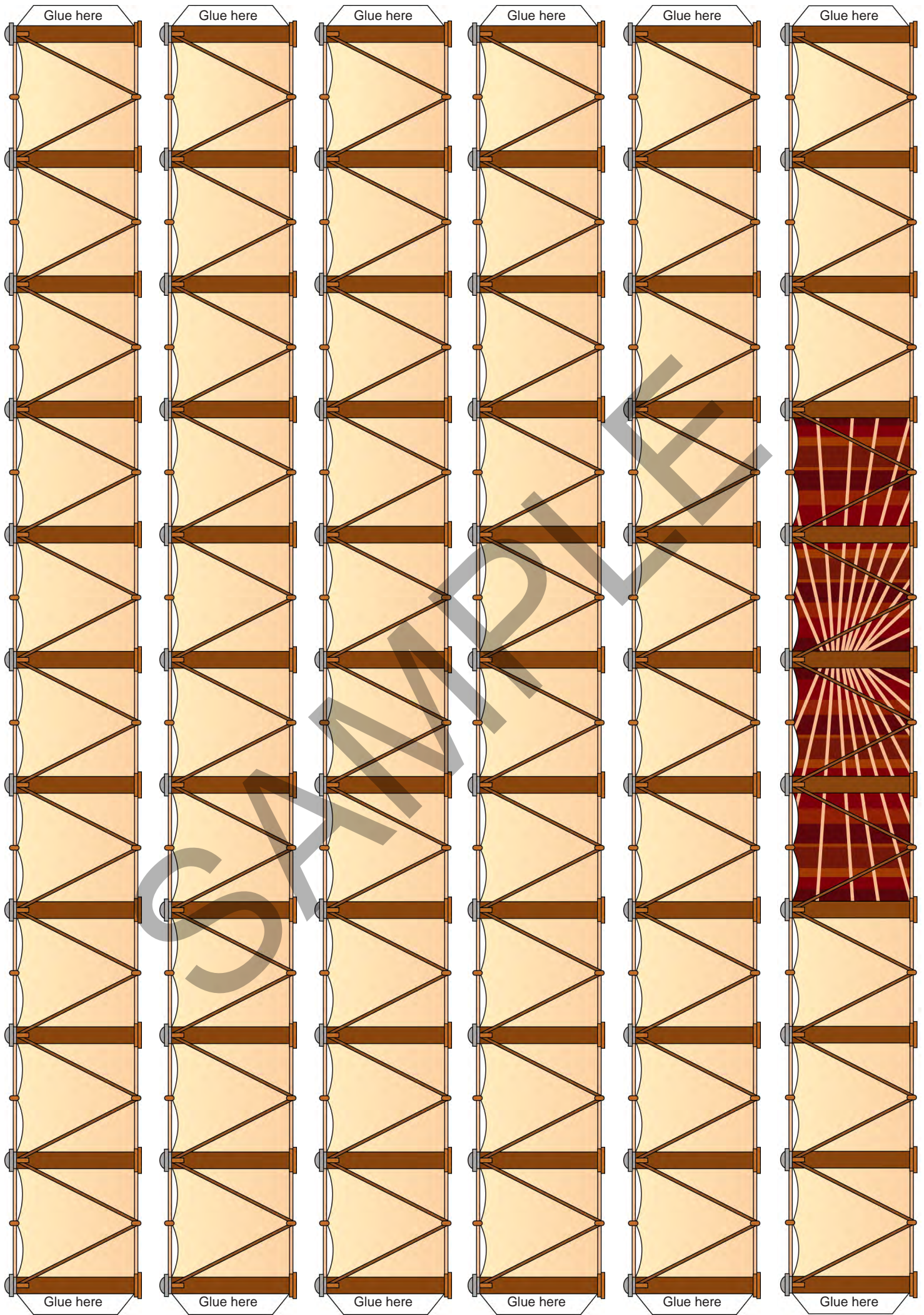

SAMPLE

(Lesson 1)

Colour, cut & paste

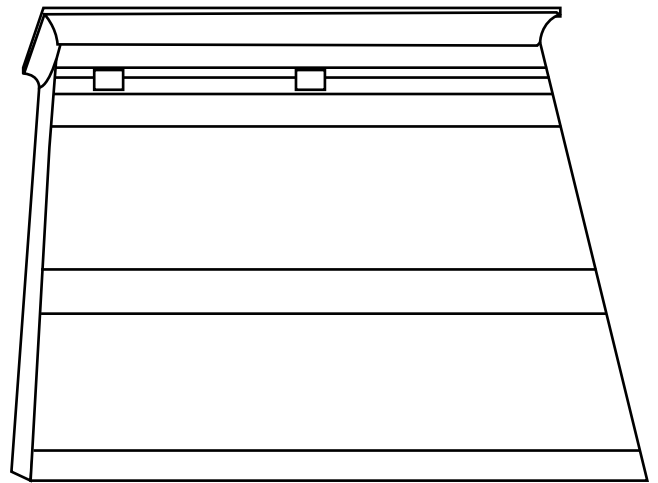
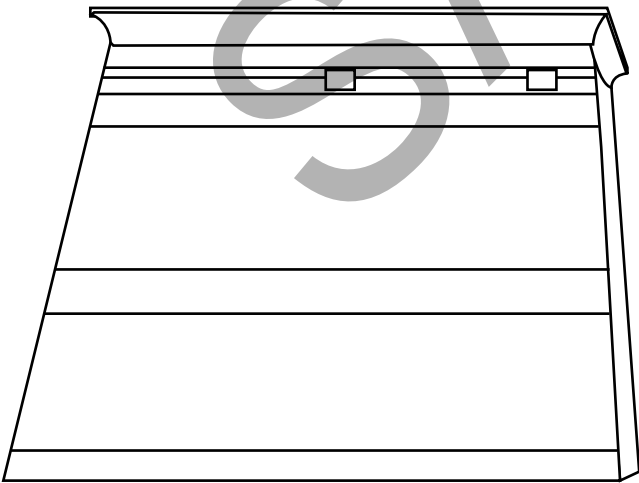
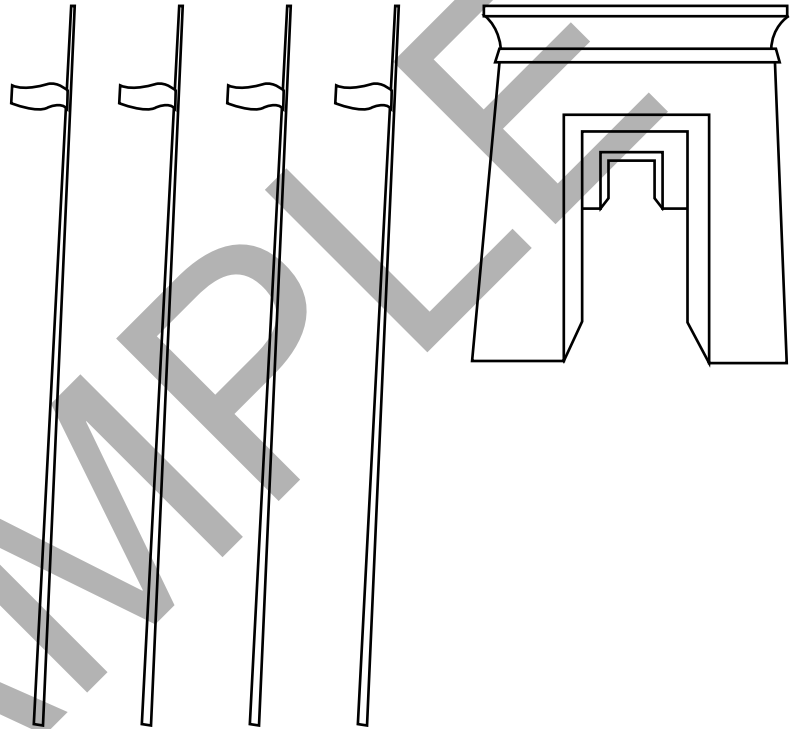
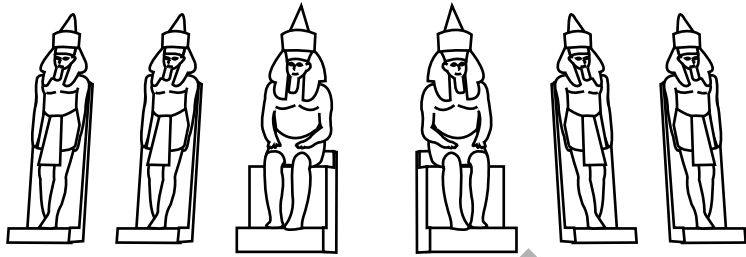
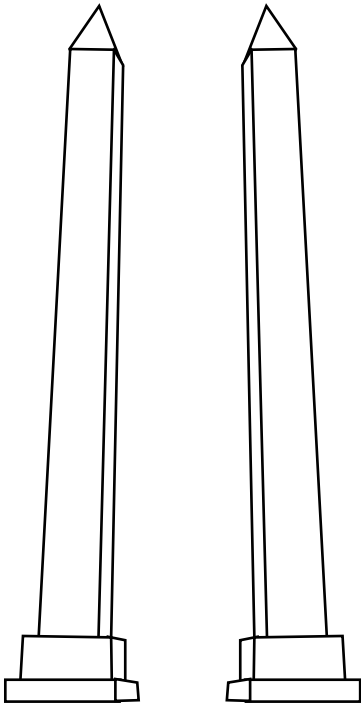

SAMPLE

(Lesson 17)

Colour, cut & paste



